

# Traclite V2

Lift Control System for Geared Traction Lifts

Lifteknic Limited

11 Victoria Road • Chester • Cheshire CH2 2AX  
Tel. +44(0)1244 389690 • Fax. +44(0)1244 389691  
<http://www.lifteknic.co.uk>

subject to change without notice!



### General Information

The manufacturer accepts no liability for any consequences resulting from inappropriate, negligent, incorrect installation or adjustment of the optional operating parameters of the equipment.

The contents of this Operating Manual are believed to be correct at the time of printing. In the interests of commitment to a policy of continuous development and improvement, the manufacturer reserves the right to change the specification of the product, its performance or the contents of the Operating Manual without notice.

All rights reserved. No part of this Operating Manual may be reproduced or transmitted in any form or by any means, electrical or mechanical including photocopying, recording or by any information storage or retrieval system, without permission in writing from the publisher.

#### Revision History

V1.0	Traclite manual updated to suit Traclite V2 control system
V1.1	DTO/DTC input positions swapped with TUP/TDN to line up with Qube control system
V2.0	Update of menu options sections

Copyright © August 2010 Lifteknik Limited

Qube® is a registered trademark

---

---

subject to change without notice!



**Contents:**

1	SAFETY INFORMATION -----	6
2	SYSTEM OVERVIEW-----	8
3	HARDWARE OVERVIEW-----	10
3.1	<i>Traclite Power System</i> -----	10
3.2	<i>Traclite Motherboard (QMB)</i> -----	10
3.3	<i>CPU Module</i> -----	11
3.4	<i>HMI - Human Machine Interface</i> -----	11
3.5	<i>Expansion I/O Module</i> -----	11
3.6	<i>Speech Card</i> -----	11
3.7	<i>Power Supply Unit</i> -----	11
3.8	<i>CAN Networks</i> -----	12
4	SYSTEM OPERATION -----	13
4.1	<i>Menu Structure</i> -----	13
4.2	<i>Menu Options</i> -----	14
4.3	<i>Status Display</i> -----	17
5	CONTROLLER CONFIGURATION -----	19
5.1	<i>System Configure [Timers]</i> -----	20
5.2	<i>System Configure [Contract]</i> -----	23
5.3	<i>System Configure [Speeds]</i> -----	28
5.4	<i>System Configure [Time &amp; Date]</i> -----	30
5.5	<i>System Configure [Call Maps]</i> -----	31
5.6	<i>System Configure [Save Config]</i> -----	33
6	ENTER CALLS -----	34
6.1	<i>Entering a Car Call</i> -----	35
7	SYSTEM EVENTS -----	36
7.1	<i>Accessing System Events</i> -----	36
7.2	<i>Event message descriptions</i> -----	38
8	SYSTEM MONITOR -----	45
8.1	<i>Floor Maps</i> -----	46
8.2	<i>QMB Motherboard &amp; I/O Block Input Status</i> -----	47
8.3	<i>QMB Motherboard &amp; I/O Block Output Status</i> -----	48
8.4	<i>Door Flag Status</i> -----	49
8.5	<i>PSE Flag Status</i> -----	50
8.6	<i>CAN Network Status</i> -----	51
9	ENGINEERS TOOLS -----	52
9.1	<i>Using Engineers Tool Options</i> -----	52
9.2	<i>Engineers Tools Descriptions</i> -----	53
10	SYSTEM I/O DESCRIPTIONS -----	54
10.1	<i>Standard Input Designations</i> -----	54
10.2	<i>Input Descriptions</i> -----	56
10.3	<i>Standard Output Designations</i> -----	63
10.4	<i>Output Descriptions</i> -----	65
10.5	<i>Call Push Interface</i> -----	69

## Operating Instructions

11	UNIVERSAL INTERFACE BOARD -----	71
11.1	<i>Switch settings for landing node</i> -----	71
12	QUICK START ROUTINE FOR TRACLITE WITH UNIDRIVE SP DRIVE -----	74
13	UNIDRIVE SP – STANDARD LIFT DRIVE -----	77
13.1	<i>Introduction</i> -----	77
13.2	<i>Assigning parameters</i> -----	77
13.3	<i>Smart card programming</i> -----	80
13.4	<i>Inverter start-up on site</i> -----	81
13.5	<i>Optimising the brake controller</i> -----	84

**LIFTEKNIC**

## Declaration Of Conformity

The Traclite control system has been designed and manufactured in accordance with the following European, national and international standards:

EN12015 : 2004	EMC Emissions
EN12016 : 2004	EMC Immunity
NEN-EN81-1 / NEN-EN81-2 *	Type Examination

\*(article 14.1.1, 14.1.2.3, annex H)



Paul Catherall  
General Manager

Lifteknic Limited  
11 Victoria Road  
Chester  
Cheshire  
CH2 2AX  
Phone +44(0) 1244 389690  
Fax +44(0) 1244 389691  
<http://www.lifteknic.co.uk>

This controller is intended to be used with an appropriate motor, drive, electrical components and other equipment to form a complete system. It must only be installed by a professional who is familiar with the requirements for safety and electromagnetic compatibility (EMC). The installer is responsible for ensuring that the end product complies with all the relevant laws of the country of installation.

## 1 Safety Information

### Assessment of risks during installation of lift control equipment

#### Personnel

All installation, commissioning and servicing of electrical and electronic components within the lift control system must be performed by, or supervised by, suitably qualified personnel (i.e. personnel that have appropriate training and knowledge of regulations that allow them to judge the quality of the work performed and identify the possible dangers). Any personnel working on Lifteknik products are responsible for their own safety.

#### Documentation

All documentation supplied with the lift control system must be made available to personnel working on the lift control equipment, with particular attention being paid to the safety notices and the recommendations contained therein.

This manual is not contract specific and must be read in conjunction with the contract electrical diagrams related to the specific lift installation(s).

#### Residual dangers

Residual dangers that exist when installing or working on lift control equipment are listed below.

##### Danger to personnel

###### Danger to life

- Risk of electric shock from live parts when working on electrical equipment.
- Risk of falling down the lift shaft when working on the car top or in the lift shaft

###### Risk of injury

- When moving or lifting control cubicle if equipment falls or tips over
- When working in lift shaft while lift is moving
- When working on control equipment that may be very hot due to recent use

##### Damage to equipment

- Risk of damage to control component's to excess voltages or short circuits

This list is not considered exhaustive and due consideration for the safety of personnel and equipment must be exercised at all times.

**Compliance with regulations**

Observation of and adherence to all applicable safety regulations, guidelines and statutory instruments is the pre-requisite for avoiding injuries to personnel and damage to the lift/elevator installation during its installation, maintenance and repair.

Reference BS7255 - Safe working on Lifts.

**Warnings**

Throughout this manual, important safety advice and danger warnings are emphasized with the following symbols:



General danger warning.



High danger risk warning.



Potential component damage from improper installation.



Important information sign.

**Liability and Guarantee**

This manual is intended for use by personnel who are familiar with the installation and maintenance of lifts/elevators. It is essential that they possess sufficient knowledge of lift/elevator construction.

Lifteknik Limited does not accept responsibility for damage incurred through unauthorised or improper actions carried out in contradiction of these instructions thereby compromising the performance or integrity of the product.

The guarantee obligations of Lifteknik Limited are rendered void if the equipment is used other than as described in these instructions.

No modifications or alterations to the circuits or components to be made without consultation and permission.

## 2 System Overview

### Introduction

The Traclite control system is the product of many years experience and investment in lift control technology. It is commitment to innovation that has seen Lifteknik rise to become one of the global market leaders for lift control systems. The Traclite controller is based on the Qube control system and optimised for use with AC geared machines with speeds up to 2.0m/s.

### Design & Build Quality

Only the highest quality components and manufacturing techniques are used throughout production, resulting in a highly reliable product that can be considered without question as a sound investment in the future of a lift installation.

### Floor Capability

The Traclite control system serves up to 20 floors in any call mode (i.e. APB, non-selective collective, down collective or full collective) when used inconjunction with a landing CAN network.

Where landing calls are wired directly back to the controller, the floor service capability is reduced to 10 floors (7 floors if Full Collective control is required).

Where DDA compatibility is required, a landing CAN network is utilised and the landing calls and associated call registration buzzer are interfaced to the main controller via a universal interface, connected to the landing CAN network at each floor.

### Door Capability

The Traclite control system provides controls for a single door operator but may be configured to operate two door operators in non-selective mode to suit the specific application.

### Drives

The Traclite control system is targeted specifically at AC geared installations operating in open loop up 1.0m/s or closed loop up to 2.0m/s.

The Unidrive SP by Control Techniques is used in conjunction with the Traclite lift control system.



**Traclite Features**

- Standard cabinet size 1200H x 600W\* x 300D (\* 720W including braking resistor)
- Integrated car interface
- Tapehead/Proximity switch positioning up to 1.0m/s (standard floor heights)
- PSE system positioning up to 1.6m/s (or for short floor operation)
- Open loop operation up to 1.0m/s
- Closed loop operation up to 1.6m/s
- Geared AC machines up to 13kW/29A (larger sizes available on request)
- Simplex or duplex operation only
- Up to 20 floors as standard (with landing CAN network)
- Direct connection of landing calls up to 10 floors, not DDA compatible
- DDA compatible landing network available
- Handwinding system c/w 24Vdc battery for buzzer & tapehead back-up supply
- Single contactor operation
- 3-wire supply (no neutral required)
- Compatible with Qube car & landing fixtures (Dot-matrix & LCD indicators and LOP's etc.)
- Available on short lead-time (standard controller can be kept in stock with required drive & braking resistor added to suit customer requirements)

### 3 Hardware Overview

#### 3.1 Traclite Power System

Safety circuit voltage - 110Vac  
Signal voltage - 24Vdc

#### 3.2 Traclite Motherboard (QMB)

##### Power supply connector (JP25)

24Vdc supply from PSU

##### Car CAN (port 1 on JP23)

CAN port for expansion I/O modules, position system encoder & Qube DMI in the lift car.

##### Landing CAN (port 2 on JP30 & JP18)

CAN port for landing calls, duplexing data & Qube DMI on landings.

##### Landing feature CAN (port 3 on JP13)

CAN communication port for additional per lift landing signals.

##### Serial port (P1)

Serial port for downloading new software.

##### Inputs (JP6, JP8 & JP4)

The inputs to the Traclite control system are connected to the left-hand side of the motherboard. Each of the three connectors has an earth pin and a common pin.

In the case of the 110Vac inputs (1-16), the common track must be connected into the control circuit return, between the supply and the return feed of the main contactors.

This is to ensure that if a problem arises with the safety circuit monitoring inputs that the main contactor return path is disabled (i.e. preventing further movement of the lift).

The input connections are arranged in the following way;

Input Connector 1 (JP6) Inputs 1-8 110Vac - safety circuit

Input Connector 2 (JP8) Inputs 9-16 110Vac - safety circuit

Input Connector 3 (JP4) Inputs 17-24 24Vdc - positioning signals

##### Outputs (JP2, JP3, JP5 & JP7)

All the outputs on the Traclite motherboard (QMB) are fed via an Output Enable relay (OEN). This relay, mounted on the top left-hand side of the QMB, ensures that the supply for the output relays is only switched on if the main program is functioning correctly.

If the main program does not execute in the correct way, the output enable relay will be released causing all output relays to be released.

The output connections are arranged in the following way;

Output Connector 1 (JP2) Outputs 1-4

Output Connector 2 (JP3) Outputs 5-8

Output Connector 3 (JP5) Outputs 9-16

Output Connector 4 (JP7) Outputs 17-24

### 3.3 CPU Module

The central processor module contains the Traclite software employs a software and hardware watchdog, that monitors code execution and resets the device if a problem is detected.

### 3.4 HMI - Human Machine Interface

The on-board HMI (Human Machine Interface) comprises a 4 line x 20 character LCD module with 4-buttons and is a simple to use, fully featured user interface that allows easy access to the Traclite system information.

Functions accessible through the HMI are listed below;

Entering calls  
Setting up contract specific parameters  
Securing floors  
Monitoring data  
Viewing system events  
Setting time and date, etc.

(see sections 4, 5 & 6)

### 3.5 Expansion I/O Module

The standard expansion I/O module consists of;

- i) 1 x 24-way CAN I/O board (24 opto-isolated inputs & 24 relay outputs)
- ii) 1 x 8-way extension I/O board (8 opto-isolated inputs & 8 relay outputs)

These boards are mounted alongside the QMB motherboard behind the perspex cover inside the controller.

The cover is idented to give a clear indication of all the input and output signals for easy diagnosis and fault-finding.

### 3.6 Speech Card

The speech card (if fitted) is mounted on a bracket at the top of the controller.

### 3.7 Power Supply Unit

A switch mode PSU is utilised for all electronics and signal supplies.

Input voltage - 85Vac - 250Vac  
Output voltage - 24Vdc @ 100W

### 3.8 CAN Networks

The Traclite control system includes 3 CAN networks as follows;

#### Car CAN (JP23)

CAN port for expansion I/O modules, position system encoder & Qube DMI in the lift car.

#### Landing CAN (JP30 & JP18)

CAN port for landing calls, duplexing data & Qube DMI on landings.

#### Landing feature CAN (JP13)

CAN communication port for additional per lift landing signals.

The basic network topology for each network is exactly the same, with a line loading resistor of 120 ohms being fitted at either end of each network as shown below.

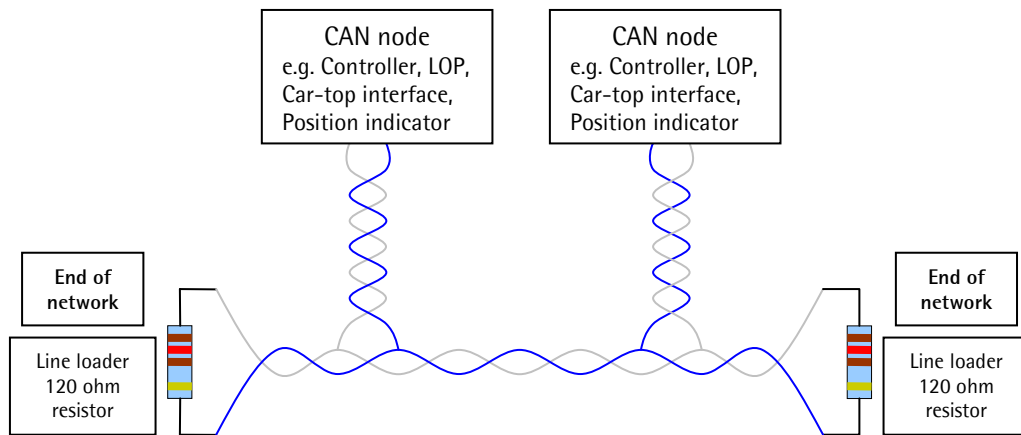

Fig: CAN Network Topology

Operating Instructions

4 System Operation

The Traclite firmware is contained in Flash memory on the CPU board mounted on the Traclite motherboard. Firmware updates can be loaded into the CPU via the serial port P1 located on the top right-hand side of the QMB.

The Traclite parameters can be modified by the user in the menu system, accessible via the MMI mounted on the QMB or via the Handheld MMI.

4.1 Menu Structure

The main menu (status display) is shown after a power-up or CPU reset.

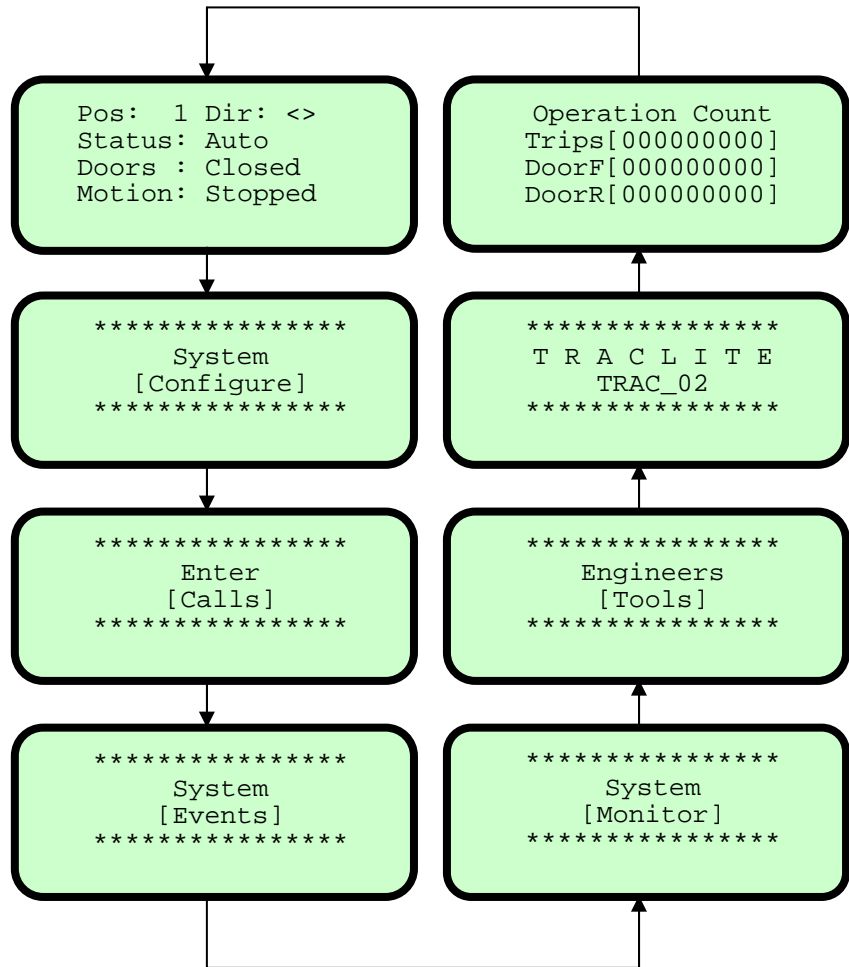

Press ↑ (anti-clockwise) or ↓ (clockwise) to view each screen in turn, then press E to enter.



Operating Instructions

## 4.2 Menu Options

Main Screen	Setting Summary	
System Configure	Timers	Tim1 Hall Dwell
		Tim2 Car Dwell
		Tim3 Rev Dwell
		Tim4 DJR Time
		Tim5 Low Speed
		Tim6 Re-level
		Tim7 Nudge Time
		Tim8 Pre-open
		Tim9 Door Hold
		Tim10 Stop Delay
		Tim11 Retry Time
		Tim12 Homing
		Tim13 Brake Switch
		Tim14 Car Light
		Tim15 Door Protection
		Tim16 Car Preference
		Tim17 Star Delta
		Tim18 PWR Sve Tim
		Tim19 PWR Recover
		Tim20 Zero Speed
		Tim21 Brake Lift
		Tim22 Brake Set
		Tim23 Hyd Homing
		Tim24 Sec Homing
		Tim25 Idle Time
		Tim26 Close Limit
	Contract	See Table in Section ??
	Speeds	PSE Resolution
		Handwind Speed Limit
		SMU Percentage
		Contract Speed
		Door Zone Speed

subject to change without notice!



	Time & Date	Set Time
		Set Date
		View Time & Date
	Call Maps	Config Blank Floors - Front
		Config Trigger Strategy - Car Front
		Config Trigger Strategy - Up Call Front
		Config Trigger Strategy - Dn Call Front
		Config Blank Floors - Rear
		Config Trigger Strategy - Car Rear
		Config Trigger Strategy - Up Call Rear
		Config Trigger Strategy - Dn Call Rear
	Save Config	Save All Settings
Enter Calls	Front Car Call	
	Front Hall Up Call	
	Front Hall Down Call	
	Rear Car Call	
	Rear Hall Up Call	
	Rear Hall Down Call	
System Events	View Log	100 Events Max.
	Download Event Data	
	Download Parameters	
	Place Engineers Entry Stamp	
	Reset & Clear Event Table	
	Reset Operations Counters	
System Monitor	Front Call 1-16	
	Front Call 17-32	
	Rear Call 1-16	
	Rear Call 17-32	
	QMB Input State	
	I/O Block 1 Input State	
	I/O Block 2 Input State	
	I/O Block 3 Input State	
	I/O Block 4 Input State	
	I/O Block 5 Input State	
	I/O Block 6 Input State	
	QMB Output State	
	I/O Block 1 Output State	
	I/O Block 2 Output State	
	I/O Block 3 Output State	

subject to change without notice!



## Operating Instructions

	I/O Block 4 Output State	
	I/O Block 5 Output State	
	I/O Block 6 Output State	
	Front Door Status	
	Rear Door Status	
	PSE System Status	
	Network 1 Status	
	Network 2 Status	
	Network 3 Status	
Engineers Tools	Prepare to Test	ON/OFF
	Door Disable	ON/OFF
	Overtravel Test	ON/OFF
	Auto Run Lift	ON/OFF
	Direct to Floor Disable	ON/OFF
	Speech Disable	ON/OFF
	WS By-pass	ON/OFF
	WS Overload	ON/OFF
	Test Event Logging	ON/OFF
	Test Car Light Fan	ON/OFF
Software Version	e.g. TRAC2 09	
Operation Counter	Journey Counter	
	Front Door Counter	
	Rear Door Counter	



## Operating Instructions

**4.3 Status Display**

```
Pos: 1 Dir: <>
Status: Auto
Doors : Closed
Motion: Stopped
```

This display provides useful data for the Engineer when working on the system.

- a) Position
- Pos:6 - Indicates the current position status of the control system
  - S:6 - Current lift position (Single-high speed system only)
  - A:8 - Current lift position (Multi-high speed system only)
  - Advanced lift position (Multi-high speed system only)  
The advanced lift position is used to look ahead for calls and for slowdown point on higher speed (i.e. typically, speed>1.6m/s) lift systems (Note A & S positions will be equal when lift is levelling or stopped)
- b) Direction
- Dir: <> - Indicates the current direction status of the control system
  - Dir: Up (Dn) - No direction
  - Dir: >Up> (<Dn<) - Committed direction of travel, lift stationary
  - Committed direction of travel, lift in motion
- c) Status
- Automatic - Indicates the current operating mode of the control system
  - Inspection - Lift is operating in normal service (accepts all calls)
  - Panel Test - Lift is operating under car top test control
  - Lift is operating under panel test control (local inspection mode)
  - Special Sv - Lift is operating under service control (car preference)
  - Disable Dr - Automatic door control is disabled
  - Safety CCT - The primary safety circuit is broken (e.g. limits, stop push, etc.. )
  - Fire Srv.1 - Lift being recalled under fire control (e.g. firefighting, alarm, etc.. )
  - Fire Srv.2 - Lift is operating under fire control
  - Shutdown - Lift has shutdown due to non-resettable fault (manual reset req'd)
- d) Doors
- Closed ][ - Indicates the current status of door movement
  - Closing >< - Doors are fully closed. (CL off AND OL on, AND GL on)
  - Opening <> - Doors are closing (command to close until closed)
  - Open [ ] - Doors are opening (command to open until open)
  - Doors are fully open. (CL on AND OL off AND GL off).

## Operating Instructions

- e) Motion - Indicates the current status of the lift movement.
- Stopped - The lift is stationary at floor level.
  - Starting - The lift is starting to move away from floor level.
  - High Speed - The lift is travelling on high speed.
  - Slowing - The lift has been commanded to slowdown.
  - Levelling - The lift is in the levelling zone preparing to stop.
  - Stop Os DZ - The lift has stopped outside the door zone.
  - Car Diving - The lift is searching for a floor to reset the system position.

The status display will show a system event as it occurs.

The event flashes on/off on the "Status:" line on the LCD display for 6 seconds, after which the display will revert to "Status:" once again. The event can be cleared immediately by pressing the E key.

Pressing and holding the E key whilst on the "Main Menu" screen displays a system summary screen. This screen shows some of the key configuration settings at a glance.

```
Lift: 1 Simplex
Bot : 1 Top : 4
Park: 1 Fire: 1
Nets: 2 SSys: 3
```

Releasing the E key returns the "Main Menu" screen.

**5 Controller Configuration**

Ensure that motor data is entered into the drive unit before the first travel on inspection control. Undertake motor self-tune if possible/applicable (refer to appendix for drive specific set-up instructions)

System Configure

```
*****  
System  
[Configure]  
*****
```

From the "System Configure" screen press E to access the sub-menu options as shown below Press ↑ or ↓ to view each screen.

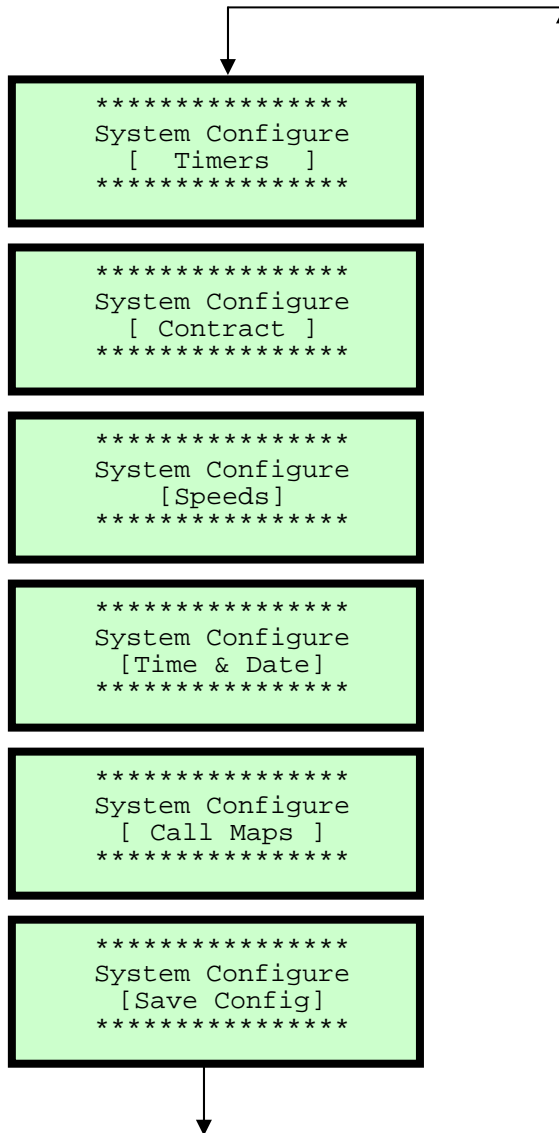

## Operating Instructions

**5.1 System Configure [Timers]**

```
*****  
System Configure  
[ Timers ]  
*****
```

From the [ Timers ] screen, press **E** to access each timer to view or change settings (see "Timer descriptions and settings table" for complete list).

Press **↑** or **↓** to view each timer

```
Tim1 Hall dwell  
* Unit:Second *  
* Value :6 *  
* New val:?? *
```

To change a timer setting press **E**

```
Tim1 Hall dwell  
* Unit:Second *  
* Value :6 *  
* New val:6 *
```

Press **↑** or **↓** to adjust the value

```
Tim1 Hall dwell  
* Unit:Second *  
* Value :6 *  
* New val:9 *
```

To accept the value press **E**

```
Tim1 Hall dwell  
* Unit:Second *  
* Value :9 *  
* New val:?? *
```

Press **↑** or **↓** to view next timer

```
Tim2 Car dwell  
* Unit:Second *  
* Value :3 *  
* New val:?? *
```

To exit timer settings, press **←**

```
*****  
System Configure  
[ Timers ]  
*****
```

## Operating Instructions

**5.1.1 Timer descriptions and settings table**

No.	Name	Description	Def'lt	Max.	Min.	Units
1	Hall dwell	Landing call dwell timer Door open dwell time after the lift has answered a landing call.	6	30	3	Secs.
2	Car dwell	Car call dwell timer Door open dwell time after the lift has answered a car call.	3	30	1	Secs.
3	Rev dwell	Differential dwell timer Door open dwell time after the doors have been re-opened by a door reversal device.	1	30	0	Secs.
4	DJR time	Motor run limit timer. Sets the time allowed for the lift to travel after the MC signal comes on. Timer is reset each time the lift changes position.	45	45	10	Secs.
5	Low speed	Low speed limit timer Sets the time allowed for the lift to reach floor after a slowdown from high speed.	30	180	5	Secs.
6	Re-level	Re-levelling limit timer. Sets the time allowed for the lift to re-level after the MC signal comes on.	10	20	4	Secs.
7	Nudge time	Door nudge timer Sets to time allowed for the doors to be continuously obstructed before nudging is initiated (if set).	20	30	3	Secs.
8	Pre-open	Pre-open delay timer. Sets the time between a valid door zone signal and a command to pre-open the doors.	4	40	1	Secs. /10
9	Door hold	Door hold open timer. Sets the time between activation of a door hold push or switch and automatic closing of the doors	60	3600	10	Secs.
10	Stop Delay	Motor contactor hold timer. Sets the time between the stop signal and the un-conditional release of the motor contactors.	10	80	1	Secs. /10
11	Retry Time	Retry after fault timer Sets the time before the lift tries to automatically re-start after a retry type fault.	180	3600	60	Secs.
12	Homing	Primary homing Timer. Sets the time before the lift returns automatically to the main floor after all calls have been serviced.	30	60	5	Secs.
13	Brake Swt	Brake Switch Timer. Sets the time allowed for the brake switch to operate after a start command has been issued.	2	7	1	Secs.

subject to change without notice!

No.	Name	Description	Def't	Max.	Min.	Unit
14	Car light	Car light timer Sets the time before the car light control is switched off after all calls have been serviced.	2	120	1	Mins.
15	Door Prot	Door open/close protection time Sets the time allowed for the doors to successfully open or close	14	30	7	Secs.
16	Car Pref	Car Preference Time Time before a hall call is allowed after the lift stops. <i>APB control only</i>	10	30	1	Secs.
17	Star Delta	Star-Delta timer Sets the time between a start command and delta contactor command. <i>Hydraulic or MG set control only.</i>	4	10	1	Secs.
18	PWR Sve Tim	Power Save Timer Sets the time before the power saving features are enabled after the last journey	15	60	1	Mins.
19	PWR Recover	Power Recovery Timer Sets the time before the lift runs after the power saving features are disabled due to a new demand	4	10	2	Secs.
20	Zero speed	Zero-speed holding time. Sets the time between brake lift confirmed and the generator field reg. pattern enable. <i>MG set control only.</i>	7	30	1	Secs. /10
21	Brake Lift	Brake lift time. Sets the time allowed for the brake to lift if brake switch is not available. <i>MG set control only.</i>	7	30	1	Secs. /10
22	Brake Set	Brake set timer. Sets the time allowed for the brake to set if brake switch is not available. <i>MG set control only.</i>	7	30	1	Secs. /10
24	Sec Homing	Secondary homing Timer. Sets the time before the lift returns automatically to the main floor after all calls have been serviced and the primary homing floor has been serviced by another lift in the group. <i>Duplex operation only</i>	60	300	60	Secs
25	Idle time		1	5	1	Mins.
26	Close limit	Close limit overdrive timer. Sets the time between loss of door close limit breaking (Input DCL) and drop of door close signal (Output DCC). Typically required for Schindler QKS door operators	3	20	1	Secs. /10

## 5.2 System Configure [Contract]

```
*****  
System Configure  
[ Contract ]  
*****
```

From the [ Contract ] screen, press **E** to access each parameter to view or change settings (see "Contract Parameter descriptions table" for complete list).

Press **↑** or **↓** to view parameters.

Bottom line of display scrolls a short description of the parameter

```
>> TOP LEVEL <<  
**** Value:6 ****  
* Change Value ? *  
Highest floor level se
```

To change parameter value press **E**

```
>> TOP LEVEL <<  
**** Value:6 ****  
* New Value:6 *  
served this value rese
```

Press **↑** or **↓** to adjust the value

```
>> TOP LEVEL <<  
**** Value:6 ****  
* New Value:8 *  
resets the selector wh
```

To accept the value press **E**

```
>> TOP LEVEL <<  
**** Value:8 ****  
* Change Value ? *  
when lift on top reset
```

Press **↑** or **↓** for next parameter

```
>> BOTTOM LEVEL <<  
**** Value:1 ****  
* Change Value ? *  
Lowest floor level ser
```

To exit parameters, press **←**

```
*****  
System Configure  
[ Contract ]  
*****
```

## 5.2.1 Contract Parameter Descriptions

Name	Description
TOP LEVEL	Highest floor level served. This value resets the selector when lift on top reset.
BOTTOM LEVEL	Lowest floor level served this value resets the selector when lift on bottom reset.
LOBBY LEVEL	Primary parking/recall floor usually the main/lobby level.
SECOND PARK LEV	Force park level for one other car or zero = Auto calculate.
PARK OPEN	1 = Park open at Lobby, 2 = Park open all floors.
FIRE RETURN LEV	Fire return level – when recall activated.
FIRE ALT LEV	Alternate fire level – if feature implemented 0= OFF.
FIRE CTRL TYPE	0=Recall ly,=BS5655,1inp/2=BS5588,1inp/3=BS5655,2inp/4=BS5588,2inp.
FIRE PARK OPEN	Doors to park open after Fire return when two stage operation.
ENABLE HOMING	Enable automatic Parking feature.
DUPLEX ENABLE	Enables Duplex/Group operation Set Car number on lifts, Lowest number is Master.
CAR NUMBER 1-2	Car Number 1-2 – number of this lift in the duplex/group 1 = master when duplex.
HOLD DIRECTION	ON = direction preference is held until doors are closed, OFF =start to close.
BEHIND CANCEL	Prevent car calls behind the car's direction of travel.
NUISANCE COUNT	0 = OFF, Set the max number of car calls allowed with no car entry/exit.
PEAK DETECT	Enables UP & DN PEAK, 0 = OFF, When set value = No. of down calls to trigger DPK.
CONST PRESS SRV	Enable Constant press close when on car service control.
PRE-OPENING	Enables pre-opening of the doors when car slows and in DZ.
HALL CALL REOPEN	Sets the maximum door reversal count from a Landing call.
STALL CLOSED	Stall doors Closed – keep door close pilot energised when doors not open/opening.
STALL MOVING	Stall doors on move – energise door close pilot when lift moving.
STALL OPEN	Stall doors Open – keep door open pilot energised when doors not close/closing.
No OF PERSON CAR	Set the max number of persons for car to provide nuisance call cancelation
ANTI QUICK REV	Set ON to add delay between door open/close change over .



Operating Instructions

MAX DOOR REV	Max door reversals allowed before Nudging (when implemented) .
GONG CHIMES	Chimes 0=(none)/1=(1Up,1Dn)/2=(1Up,2Dn)/3=(2Up,1Dn)/4=(2Up,2Dn).
HALL LANTERNS	OFF = External Hall lanterns connected, ON = Indicator display used for Hall lanterns.
NO ROLL DISPLAY	Prevents the position indicator display from rolling when Qube Ind's used.
2 SPEED DISPLAY	Changes roll speed on position indicator display on slowing when Qube Ind's used.
POSITION DISPLAY	1=GF,1-15/2=LG,GF,1-14/3=LB,B,GF,1-13/4=LB,B,LG,GF,1-12/5=1-16/6=B,GF,1-14/7=Custom
POSITION OFFSET	Position offset value :- can be used to add an offset to POSITION CHARS.
SPEECH OFFSET	Speech offset value :- can be used to add an offset to speech messages.
VERT HALL IND	When set the Hall position display is rotated 90 degree's (Overridden by Indicator Switch).
VERT CAR IND	When set ON the Car position display is rotated 90 degree's (Overridden by Indicator Switch).
INSPECTION MESS	When on test ctrl ON= ENGINEER ON SITE, OFF= OUT OF SERVICE (Display >V7.n only) .
SECURE STRATEGY	Secure. 0=OFF/1=Input/2=Up calls/3=Down calls/4=Car calls/5=Up & down calls/6=All calls.
CYCLE LIFT/LEVEL	Cycle. 0=OFF/(n)=Lift will travel between the LOBBY LEVEL and (n) continuously.
TYPE OF CONTROL	Type of call control - 1=Full/2=Down/3=Non Selective/4=FAPB
TYPE OF DOORS	Type of doors - 1=Automatic/2=Swing landing/3=Manual gates
SMU MONITOR	Speed limit monitor check enable - monitors speed trip signal from SMU
INVERT TFR/BFR	Invert the terminal reset switch signals, default is N/O
NUMBER OF SPEEDS	Number of Individual High speed selections
BINARY SPEED	Convert speed selection to Binary
LAND FEATURE NET	Selects the network used for Pos Ind's/Hall lantern 1= STD/2=JP13 for group
DISCRETE ACCEPT	Enables use of discrete accept messages on 2x2 & 4x4 (V7.n or higher)
NUDGING ENABLE	Door nudging enable (reduced torque closing of doors)
ZONE LOCK MODE	Zone locking invert (OFF = ZLR OFF WHEN DOORS IN USE, 1= ITS INVERSE)
DRIVE SELECTION	5=UnidriveSP
FIRE SWT RESET	This enables the Fire operation Phase 2 to be reset to Phase 1 10sec delay
BRAKE MONITORING	Enable Brake monitoring 0= OFF, 1= Lifted switch,2= Lifted switch and Wear

subject to change without notice!



## Operating Instructions

RE-LEVEL ENABLE	This enables the Re-levelling operation
NUM OF ENTRANCES	Sets the number of door entrances e.g. FRONT AND REAR = 2
SELECTIVE DOORS	Set to enable fully selective rear door entrance functions
TEST UP LIMIT	This enables the test up limit (when used) to stop the car
TEST DOOR LIMITS	This enables the car door limits to be referenced when on inspection
DEBOUNCE JP6	This value allows input loss to be delayed in 40ms increments
PSE RST SWT LEV	Level of the reset switch for the PSE position encoder device
SHAFT SYSTEM	1= 3 Magnets, 2= 5 Magnets, 3= PSE Encoder Type 1, 4= PSE Encoder Type 2
IND LANGUAGE	1= English,2= Francais,3= Deutsch. Text on indicators
HOT_TEST x10	Number of stops for Hot Testing
IO SYSTEM	1= No Landing Network, landing calls wired to controller 2= WITH LANDING NETWORK
FLOOR MASKING	Open-Fail masking of floor levels from landing calls OFF= Disable, ON= Enable
SE_PHASE_1	Enables safety edge to work on phase 1 fire service OFF= Disable, ON= Enable
QUICK CLOSE	Enables Quick Close 0 = Off, 1 = 4 Wire Calls 2 = 3 Wire Calls
SHOW BLANK FLR	If set to 1 shows blanked floors on the indicators
INVERT SAFE EDGE	If set to 1 Safe Edge is N/C else if set to 0 N/O contact is used
SET IND & SPEECH	0 = All floors, 1 = EVEN floors, 2 = ODD with common bottom floor, 3 = ODD floors,
COMMON TOP FLOOR	Skip stop with common top floor. 0 = Different, 1 = Common
INDICATOR TYPE	0 = Off, 1 = Discrete, 2 = Binary, 3 = Gray Code
BINARY OFFSET	Sets offset for binary outputs POA to POD
INV DOOR LIMITS	If set to ON Door Limits are N/O else if set to OFF N/C contact is used
LCD IND MODE	Sets mode of LCD Indicators
LCD OFFSET	Sets offset for LCD position display
INV FIRE INPUT	If set ON, Fire Alarm/Switch are N/C contacts
MP3 SPEECH CARD	If set to ON new speech card type with plug in SD card used
ENABLE PWR SAVE	

subject to change without notice!



TEST BOARD MODE	Set this parameter to enable board test mode
-----------------	--

**5.3 System Configure [Speeds]**

```
*****  
System Configure  
[Speeds]  
*****
```

From the [ Speeds ] screen, press **E** to view or change the lift speed related settings.  
(see "Speed Parameter Descriptions" for complete list).

Press **↑** or **↓** to view parameters.

Bottom line of display scrolls a short description of the parameter

```
>> PSE RESOLUTION <<  
** Value:32 **  
* Change Value ? *  
Set the resolution of
```

To change parameter value press **E**

```
>> PSE RESOLUTION <<  
** Value:32 **  
* New Value:32 *  
the Position System
```

Press **↑** or **↓** to adjust the value

```
>> PSE RESOLUTION <<  
** Value:32 **  
* New Value:21 *  
Encoder pp/cm <
```

To accept the value press **E**

```
>> PSE RESOLUTION <<  
**** Value:21 ****  
* Change Value ? *  
Set the resolution o
```

Press **↑** or **↓** for next parameter

```
>>HANDWIND SPD LIM<<  
**** Value:25 ****  
* Change Value ? *  
Set the max speed li
```

To exit parameters, press **←**

```
*****  
System Configure  
[Speeds]  
*****
```

**Speed Parameter Descriptions**

Name	Description
PSE RESOLUTION	Sets the resolution of the Position System Encoder pulses/cm. Used to scale display to show correct speed.
HANDWIND SPD LIM	Sets the max speed limit (cm/sec) when using electrical brake release (MRL & gearless only)
SMU PERCENTAGE	Set the percentage of contract speed that SMU becomes active
CONTRACT SPEED	Set the contract speed in cm/sec (max achievable V3)
DOOR_ZONE_SPEED	Set the maximum travel speed at which the doors are allowed to start opening

**5.4 System Configure [Time & Date]**

```
*****  
System Configure  
[Time & Date]  
*****
```

From the [ Time & Date ] screen, press **E** to view or change the time and date settings.

Press **↑** or **↓** to for options.

```
*****  
Set  
[ Time ]  
*****
```

To change time or date, press **E**

```
*****  
Set  
[ Date ]  
*****
```

To view current settings, press **E**

```
*****  
View  
[ Time & Date ]  
*****
```

```
* System date: *  
*             *  
* 01/01/2000 *  
* 00:00:00 Hrs *  
*             *
```

To exit parameters, press **←**

```
*****  
Set  
[ Time ]  
*****
```

Operating Instructions

5.5 System Configure [Call Maps]

```
*****  
System Configure  
[ Call Maps ]  
*****
```

From the [ Call Maps ] screen,  
Press **E** to blank off a floor, or to  
secure / unsecure specific entrances  
in the building.

Press **↑** or **↓** to for options.

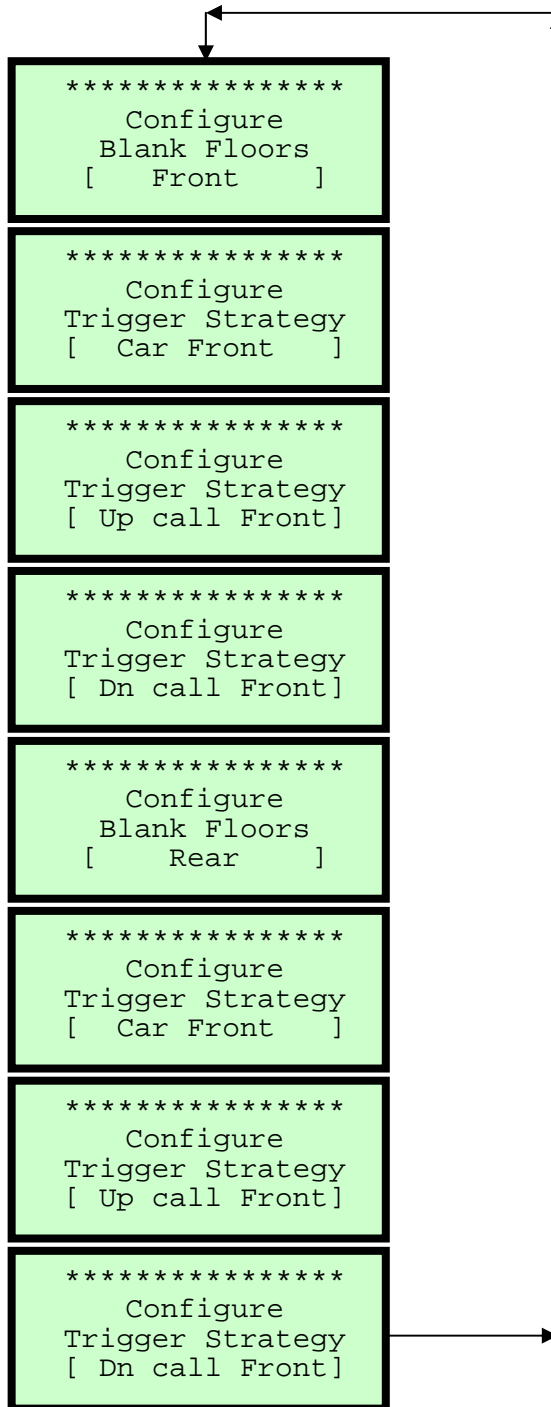

To exit Call Maps, press **←**

## Operating Instructions

When the lift serves front & rear entrances, the car & landing calls for any entrance not served by the lift should be blanked out using the "Blank Floors [Front]" & "Blank Floors [Rear]" functions.

To blank a front floor, press **E**

```
*****
Configure
Blank Floors
[ Front ]
```

Press **↑** or **↓** to select floor

```
Blank Floor
Enable-disable
ALL - Calls @
Level:1 Allowed
```

To blank the floor, press **E**

```
Blank Floor
Enable-disable
ALL - Calls @
Level:1 Secured
```

Note: Pressing **E** toggles the blank floor status between Allowed/Secured

Press **↑** or **↓** to select next floor

```
Blank Floor
Enable-disable
ALL - Calls @
Level:2 Allowed
```

To exit, press **←**

```
*****
Configure
Blank Floors
[ Front ]
```

Individual calls may be secured in a similar way by using the Trigger Strategy screens (shown on previous page).

Once set up, these strategies can be implemented on an input (keyswitch, timeclock etc.) to allow securing of specific calls by building security systems or by setting the "SECURE STRATEGY" parameter in "System Configure [Contract]".



5.6 System Configure [Save Config]

```
*****  
System Configure  
[Save Config]  
*****
```

From the [ Save Config ] screen, press **E** to save the current configuration.

To save settings, Press **E**

```
*****  
Save New  
Settings ?  
*****
```

To confirm save, Press **E**  
Or press ← to exit

```
*****  
* Are you *  
* sure ? *  
No - - - - Yes
```

```
*****  
Please Wait  
Burn in progress  
*****
```

```
*****  
Settings  
Saved!  
*****
```

To exit, Press ←

```
*****  
System Configure  
[Save Config]  
*****
```

Operating Instructions

**6 Enter Calls**

When the lift is operating on Normal Control, it is possible to enter any "allowed" call via the keypad, described as follows.

Checking the "System Monitor" will indicated which calls are allowed/secured.

```
*****  
Enter  
[Calls]  
*****
```

From the "Enter Calls" screen press E to access the sub-menu options as shown below Press ↑ or ↓ to view each screen.

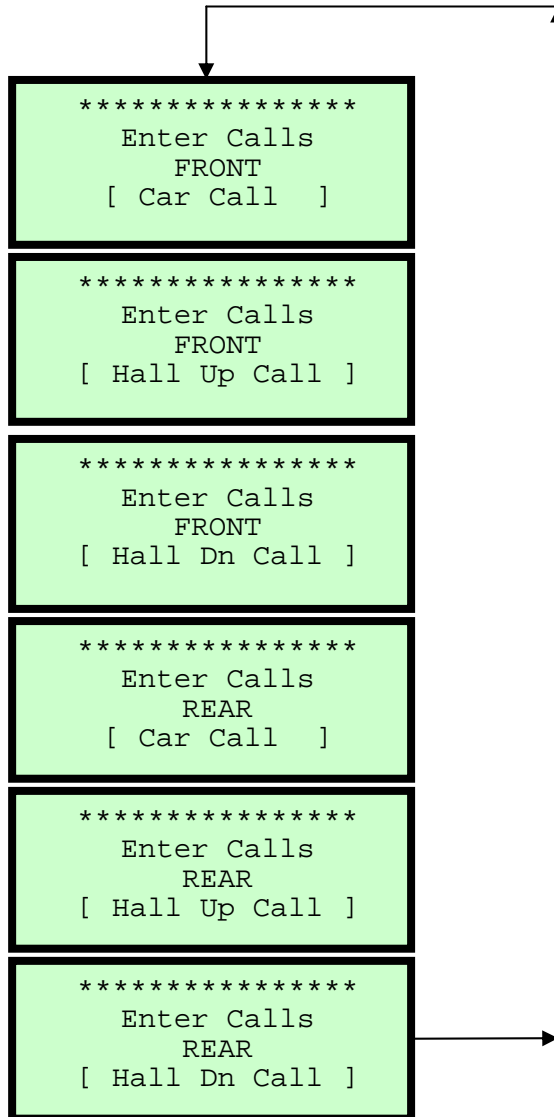

## Operating Instructions

**6.1 Entering a Car Call**

Each of the "Enter Calls" functions work in the same way

To enter a front car call, press **E**

```
*****  
Enter Calls  
FRONT  
[ Car Call ]
```

Press **↑** or **↓** to select floor

```
Ent Call at:2  
Pos:1  
Doors : Closed  
Stopped M/s 0.00
```

To enter call, press **E**

```
Ent Call at:2  
Pos:1 Done  
Doors : Closed  
Stopped M/s 0.00
```

Note: If call is accepted, "Done" is displayed but if the call is secured or the lift is not on Normal control, then "Failed" is displayed.

Press **↑** or **↓** to select next floor

```
Ent Call at:4  
Pos:2  
Doors : Closed  
Stopped M/s 0.00
```

To enter call, press **E**

```
Ent Call at:4  
Pos:2 Failed  
Doors : Closed  
Stopped M/s 0.00
```

To exit, press **←**

```
*****  
Enter Calls  
FRONT  
[ Car Call ]
```

## 7 System Events

The Traclite Micro has a large number of specific event messages, designed to give concise information about the operating history of the control system.

The event messages provide information about the operating mode of the lift controller (e.g. Fire Control, Special Service etc..) and fault finding information in the event of a fault or failure. The event logger stores up to 100 events and when the event logger is full, a new event is stored and the oldest event drops out of the log.

### 7.1 Accessing System Events

To access the "System Events" screen, press ↓ or ↑ from the "Main Menu" screen, until the following screen appears.

```
*****  
System  
Events  
*****
```

Press **E** to enter the system event menu and use ↓ or ↑ to view the system event options.

#### Accessing Event Logger

```
* System Events *  
** View Log **  
** Total Events **  
** :xxx **  
** **
```

```
PROCESSOR RESET  
No.015 Occur:001  
02/07/03 Pos: 07  
15:47:42 Adv: 07
```

#### Event Screen Detail

##### EVENT TEXT

- No. - position of event in log
- Occur - number of occurrences of a given event since the log was last cleared.
- Date - dd/mm/yy
- Pos - actual position when event occurred
- Time - hh:mm:ss
- Adv - advance position when event occurred

Pressing **E** whilst a given event is displayed will show a line of help text that scrolls across the bottom of the screen.

Pressing **E** again will show the status of the QMB inputs/outputs at the instant of the event.

## Operating Instructions

Resetting the event log, journey/door operation counters and placing a marker event in the event log can all be done in the "System Events" menu by accessing the screens shown below.

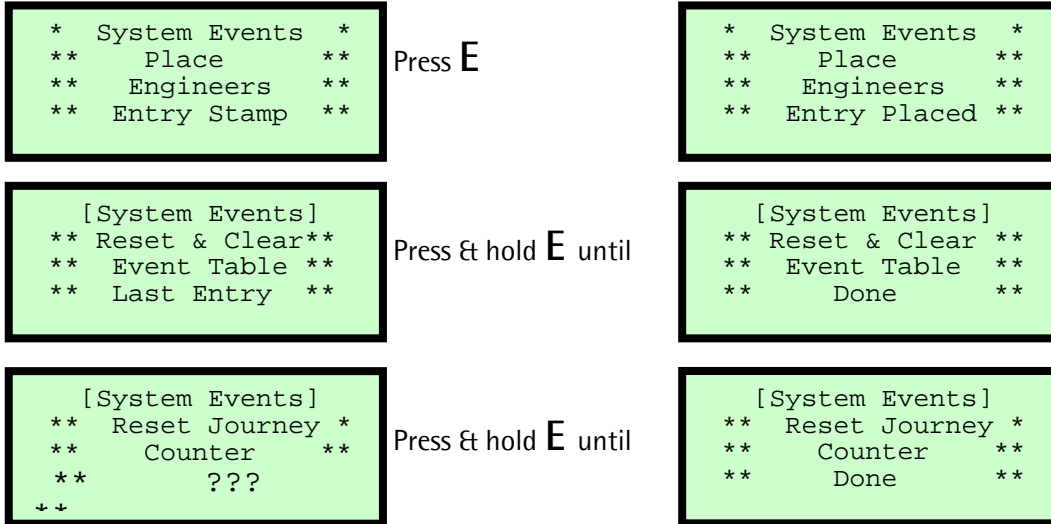

Note: The event log and the journey/door operation counters should always be reset/cleared before putting the lift in service after initial installation only.

## 7.2 Event message descriptions

A complete listing of events is shown below along with a short description.

*\* The help text that is displayed on the LCD screen is shown in italics \**

Event	Name	Description	Event Type
0	SYSTEM CHECK OK		Standard
1	GATE LOCK 1 TIP	Car gate contact opened during travel. Lift will stop immediately, unless re-levelling or ADO is in progress. <i>* The car gate (GATE LOCK 1) opened while car was moving - Doors relaxed open - Set STALL CLOSED Parameter *</i>	Standard
2	DIRECTION ERROR	Lift is travelling in the wrong direction. Error is logged if TFR signal comes on during down travel or BFR signal comes on during up travel.	Standard
3	SAFETY CCT OPEN	The primary safety circuit has been interrupted, NORMAL, TEST & EMOP inputs are all OFF. <i>* CHECK - Overtravel Limit, Buffer Switch, Overspeed Governor, Safety Gear Switch or Emergency Stop operated *</i>	Disable calls _park open_retry
4	DOUBLE JOURNEY	The motor run time limit has been exceeded. <i>* No change of position detected within DJR Time period (TIMER 3) - CHECK - Motor Drive stalled, Stepping signals *</i>	Disable calls _park open
5	START FAILURE	No "MOTOR RUNNING" input received within a few seconds of a start command being issued. <i>* CHECK - QK3, K1 and K2 Relays come in, Drive for errors, Brake lifts when requested *</i>	Standard
6	FAILED TO ESC DZ	The lift has failed to escape from floor after starting. Error is logged if the system does not lose the floor level or door zone signals within a few seconds after the "MOTOR RUNNING" input comes on. <i>* DOOR ZONE signal was not lost within the pre-set time - CHECK - If lift moves or DOOR ZONE signal stuck on *</i>	Standard
7	DRIVE OFF SHUTDN	The drive is off-line and the system has shutdown. Error is logged if the drive ok signal is lost. When in this condition the system will attempt to reset the drive (if available). <i>* The Motor Drive unit is off-line or DRIVE OK Input has been lost - CHECK - Drive for error or wiring fault *</i>	Disable calls _park open_retry
8	MC LOST IN MOTN	The lift has stopped unexpectedly during travel. Error is logged if the "MOTOR RUNNING" input has been lost before a stop command is given. <i>* CHECK - If no GATE LOCK 2 TIP event - Loose wire on K1/K2 contactors, K1 or K2 contact failure *</i>	Standard

9	LOW SPEED TIMER	The lift has failed to stop after slowdown. Error is logged if the system does not receive a stop signal within the "Low speed time" after the slowdown signal is given <i>* The lift slowed but failed to find floor level in pre-set time - CHECK - Stepping pulses - Magnet moved or missing *</i>	Standard
10	LEVELING FAILURE	The door zone/levelling signals have operated incorrectly. Error is logged if one of the door zone or levelling signals stays on during normal travel. Any ADO or re-levelling operations are subsequently disabled. <i>* The lift stopping sequence was not correct, a leveling / door zone signal stayed on during travel *</i>	Standard
11	DOORS HELD	The doors have been held open excessively by lift user.	Standard
12	DOOR OPEN FAIL	The doors have failed to open fully. Error is logged if the DOL signal is not lost within the "Door protection time" after the open command is given. <i>* The OPEN LIMIT was not lost within the door protection time (TIMER 14) - CHECK - Door Limits operate correctly *</i>	Standard
13	SYSTEM CHK OK 1		Standard
14	GATE LOCK 2 TIP	Landing gate contact opened during travel. Error is logged if GL2 signal is lost unexpectedly during travel. Lift will stop immediately, unless re-levelling or ADO is in progress. <i>* Landing Gate (GATE LOCK 2) lost while travelling - CHECK - Clearances of Locks *</i>	Standard
15	EVENT DOWNLOAD	The event log data has been downloaded from the controller via the serial communications port. <i>* The contents of the Event Logger have been downloaded to an external device *</i>	Standard
16	FIRE CONTROL	The firemans control switch adjacent to the main floor landing entrance has been activated. <i>*Fire Control has been activated *</i>	Standard
17	SPECIAL SERVICE	The service/goods keyswitch in the lift car has been activated <i>*Special Service has been activated *</i>	Standard
18	CAR STATION LOST		Standard
19	LAND PUSH LOST		Standard
20	ALARM PRESSED	The Alarm button in the lift car has been pressed	Standard
21	ENGINEERS ENTRY	The engineer has entered a reference marker in the event list <i>* An Engineer has put a reference marker in the Event Logger *</i>	Standard
22	CLOCK RESET	The real time clock on the motherboard has been reset or adjusted via the MMI	Standard

23	SMU LIMIT TRIP	The speed monitor limit has been activated. Error is logged if the SMU limit signal is lost during travel. This means that the lift was travelling too fast when approaching the top or bottom of the shaft <i>* The Lift approached terminal floor too fast - CHECK - rated speed, Missing Stepping Signal, Speed Monitor *</i>	Disable calls _park open
24	BRAKE LIFT FAIL	<i>* The Brake failed to lift - CHECK - Brake voltage, Brake lift contactor is making up *</i>	Standard
25	RESERVED 1		Standard
26	INSPECTION CTRL	The selector switch on the car-top has been switched to inspection. <i>* The lift was turned to Car Top Control *</i>	Standard
27	OUT OF SERVICE	The lift has gone out of service due to a fault	Disable calls _park open
28	EMERGENCY RETURN	The emergency recall system has been activated	Standard
29	MULT CLOSE FAILS	<i>* Doors failed to close after 3 attempts - CHECK - DCL is lost, GATE LOCKS are made, door operates correctly *</i>	Standard
30	MULT OPEN FAILS	<i>* Doors failed to open after 3 attempts - CHECK - DOL is lost when door fully open, door operates correctly *</i>	Standard
31	PFRR FAULT	The phase monitoring device has tripped due to phase loss, reversal or imbalance. <i>* A low voltage on one or more phases or a motor overheat condition exists - CHECK - Voltage between phases, Motor Thermistor *</i>	Standard
32	CLOSE FAILED	The doors have failed to fully close within the allowed time. <i>* DOOR CLOSE LIMIT was not lost or GATE LOCKS failed to make up within set time (TIMER 14) *</i>	Standard
33	UP FROM TOP	The lift has attempted to travel up from the top floor	Standard
34	DN FROM BOTTOM	The lift has attempted to travel down from the bottom floor	Standard
35	NO DIRECTION SET		Standard
36	PROCESSOR RESET	<i>* The microprocessor has been reset or power applied to the lift control panel *</i>	Standard
37	DRIVE OFF LINE	<i>* The Motor Drive has gone off line - CHECK - For errors in the Drive, DRIVE OK signal missing *</i>	Standard
38	SMU CHECK HSPEED	Speed checking signal did not turn off during a high speed run.	Disable calls _park open
39	SMU CHECK STOP	Speed checking signal is off whilst the lift is stationary.	Disable calls _park open
40	SMU CHECK SLOW	Speed checking signal did not turn on during slowdown.	Disable calls _park open
41	JOURNEY CNT RST	<i>* The Journey Counter has been reset to zero from the MMI *</i>	Standard



42	LAZY HANGER TIP	<i>* A lazy hanger contact has been broken during travel or at a different position to the lift *</i>	Disable calls _park closed
43	EEPROM ERROR	<i>* The system EEPROM for storing configuration data is faulty - Contact Lifteknik for replacement board *</i>	Disable calls _park open
44	NET 1 PROCESS	<i>* The Car Network has reset - CHECK - Cable screen is earthed, Faulty device on bus, Electrical noise problem, Wiring fault *</i>	Standard
45	CAR OVERLOADED	The 110% load switch has been activated whilst the lift is stationary	Standard
46	MULT START FAILS	<i>* The lift has failed to start after 3 attempts *</i>	Standard
47	CAR PUSH STUCK	<i>* A stuck Car Call has been present for 3 minutes - CHECK - Car push at floor indicated</i>	Standard
48	UP PUSH STUCK ON	<i>* A stuck Landing Up push has been present for 3 minutes - CHECK - Landing Up push at floor indicated *</i>	Standard
49	DN PUSH STUCK ON	<i>* A stuck Landing Down push has been present for 3 minutes - CHECK - Landing Down push at floor indicated *</i>	Standard
50	GATE LOCKS SHORT	<i>* One or both GATE LOCK signals were present when the doors were fully open - CHECK - Gate Locks being shorted *</i>	Cancel calls _pause
51	NET 2 PROCESS	<i>* Landing Network has reset - CHECK - cable is not run near Motor Cables or Drive, LC2(LLO) &amp; LC5(LHI) not swapped *</i>	Standard
52	EVENTS CLEARED	<i>* The Event Logger has has been cleared from the MMI *</i>	Standard
53	BRAKE LIFT FAIL	<i>* The Brake Switch has not operated in the set time - CHECK - (TIMER 21) and Brake Switch operation *</i>	Standard
54	BRAKE WEAR	<i>* The Shoes of the Brake have worn low or the Brake Wear Switch is defective *</i>	Standard
55	CLOSE TIMEOUT	<i>* Either DOOR CLOSE LIMIT was not lost or GATE LOCKS not made within the set time (TIMER 14) *</i>	Disable calls _park open
56	STOP OUTSIDE DZ	<i>* The lift has stopped outside of floor level or no Door Zone signal was present</i>	Standard
57	CONTACTOR STUCK	<i>* The Main Contactor has not dropped out before starting *</i>	Standard
58	BOT RESET SLOW	Bottom slowing limit has been reached without prior slowdown message from position system <i>The Bottom Floor Reset reached before slowing commenced - CHECK - Stepping signals, Faulty Reset Switch *</i>	Disable calls _park open
59	TOP RESET SLOW	Top slowing limit has been reached without prior slowdown message from position system <i>* The Top Floor Reset reached before slowing commenced - CHECK - Stepping signals, Faulty Reset Switch *</i>	Disable calls _park open
60	MULT BRAKE FAULT	The brake has failed to lift after three successive attempts	Disable calls _park open
61	ZERO MOVEMENT	No movement signal from drive has been detected after speed command issued	Cancel calls _pause
62	RAMP SWT FAULT	<i>* The door Retiring Ramp Switch was not detected</i>	Cancel calls

subject to change without notice!



Operating Instructions

		<i>when operated - CHECK - Ramp Voltage, wiring, Ramp coil *</i>	_pause
63	EMOP CONTROL	<i>* The lift was switched to Emergency Operation *</i>	Standard
64	AUTO CONTROL	<i>* The lift was switched to Automatic Operation *</i>	Standard
65	PARAM DOWNLOAD	<i>* The System Parameters have been downloaded to an external device *</i>	Standard
66	MBX TRIGGERED	Lift has slowed on a Music box (speed monitor/policing limit)	Disable calls _park open
69	OVERTRAVEL TRIP	The Overtravel limit has been operated (Hydraulic only)	Disable calls _park open
70	ENGINEER ON SITE	<i>* An Engineer has logged on site via a keypad or lift switched to EMOP or Inspection *</i>	Standard
71	ENGINEER OFFSITE	<i>* An Engineer has logged off site via a keypad *</i>	Standard
72	1000 NEW STARTS	<i>* Lift has made 1000 starts since last occurrence of this event *</i>	Standard
73	2000 DOOR OPS F	<i>* Front doors have opened 2000 times since last occurrence of this event *</i>	Standard
74	2000 DOOR OPS R	<i>* Rear doors have opened 2000 times since last occurrence of this event *</i>	Standard
75	LIFT AVAILABLE	<i>* The Lift has returned to service after being Out of Service *</i>	Standard
76	LANDING LOCK 1 TIP	<i>* Landing Gate Lock at Floor 1 opened while the lift was at another floor *</i>	Standard
77	LANDING LOCK 2 TIP	<i>* Landing Gate Lock at Floor 2 opened while the lift was at another floor *</i>	Standard
78	LANDING LOCK 3 TIP	<i>* Landing Gate Lock at Floor 3 opened while the lift was at another floor *</i>	Standard
79	LANDING LOCK 4 TIP	<i>* Landing Gate Lock at Floor 4 opened while the lift was at another floor *</i>	Standard
80	ARD INITIATED	<i>* Automatic Recovery Device has been activated due to Power Failure *</i>	Standard
81	ARD TERMINATED	<i>* Automatic Recovery has been terminated after power restoration *</i>	Standard
82	IN CAR INSPECTION	<i>* The In-Car Inspection Switch has been operated *</i>	Standard
83		<i>* One of the subsidiary device boards has failed *</i>	Standard
84	RESET LIMIT FAULT	<i>* Both the Terminal Resets (TFR BFR) are active at the same time - CHECK - Parameter INV BFR/TFR, Wiring *</i>	
85	PRE OPENING FAILED	<i>* Door Pre-Opening failed, Gate Locks not bridged - CHECK - Operation of HSP01 Safety Board and K4 Relay *</i>	
86	BYPASS 90%	<i>* The lift was loaded to 90% of its capacity *</i>	
87	LIMIT TRIP	<i>* Either Speed Monitoring tripped or Up/Down Limit at Terminal Floor broken (SMT/SMB UL/DL) *</i>	
88	EM STOP OPERATED	<i>* The in-car Emergency Stop Switch has been pressed *</i>	
89	NO MG START	<i>* The MG SET failed to start or No contact from MG SET was output *</i>	

subject to change without notice!



90	NO DELTA CONTACT	<i>* There was no changover from STAR to DELTA contacts - check Star/Delta Timer (TIMER 17) *</i>	
91	K1/2 DID NOT COME IN	<i>* The main running contactors K1, K2 did not energise - check panel circuit drawings *</i>	
92	LIFT FAILED TO MOVE	<i>* After Direction and Run outputs were set the lift failed to move - check motor drive and position encoder *</i>	Standard

The following events are all associated with PSE operation

101	PSE OVERSPEED	<i>* Speed greater than the Programmed High Speed - CHECK - Programmed Encoder Resolution, Actual Speed of lift *</i>	Standard
102	PSE O/SPEED RLEV	<i>* Releveling Speed too high - CHECK - Programmed Encoder Resolution, Actual Releveling Speed of lift *</i>	Standard
103	PSE MAGNET DIFF	<i>* A Door Zone magnet has moved since the shaft was learned - CHECK - Magnet positions and Glue Magnets after correction *</i>	Standard
104	PSE MAGNET FAULT	<i>* Missing Door Zone Magnet - CHECK - If Magnet has moved or fallen off, Clearance between Magnet and Switch *</i>	Standard
105	PSE NO MOVEMENT	<i>* No movement detected after speed command issued - CHECK - Drive for errors, Starting sequence K1 K2 Relays *</i>	Standard
106	PSE DIR ROTATION	<i>* Lift moved in the opposite direction to that issued - CHECK - For swapped phase on Motor wiring *</i>	Standard
107	PSE ZERO PULSE	<i>* No zero pulse from the encoder - CHECK - Encoder is not slipping, Screen on encoder cable is Earthed *</i>	Standard
108	PSE CAN OVERUN	<i>* Encoder Communications are unstable - CHECK - Encoder Cable screen is Earthed, CHI and CLO are not swapped *</i>	Standard
109	PSE CAN BUSOFF	<i>* Encoder communications have shutdown - CHECK - Encoder Cable screen is Earthed, CHI and CLO are not swapped *</i>	Standard
110	PSE ACKNOWLEDGE	<i>* Encoder system has not acknowledged a target command - CHECK - Encoder Cable screen is Earthed correctly *</i>	Standard
111	PSE DIR REPLY	<i>* Encoder has replied with a different direction than expected - CHECK - Encoder Cable screen is Earthed correctly *</i>	Standard
112	PSE SPEED REPLY	<i>* Encoder system has not issued a start speed to controller - CHECK - Encoder Cable screen is Earthed correctly *</i>	Standard
113	PSE COMMS LOST	<i>* Encoder Communications lost - CHECK - Encoder Cable not screened, CHI, CLO swapped, disconnected wire *</i>	Standard
114	PSE NOT VALID	<i>* Encoder has not seen the mid-shaft Reset Magnet - CHECK - Reset Magnet position, Clearance between Magnet and Switch *</i>	Standard
115	HANDTERM COM	<i>* Handterminal communication lost during learn</i>	Standard

subject to change without notice!



	LOST	<i>process - CHECK - Handterminal Cable screen not Earthed, Loose wire *</i>	
116	NET 1 OVERUN	<i>* Car Network has become unstable - CHECK - Cable screening is Earthed, Loose wire CHI or CLO *</i>	Standard
117	NET 1 BUSOFF	<i>* Car Network has shutdown - CHECK - Cable not screened, CHI and CLO swapped, Disconnected or Loose wire *</i>	Standard
118	POS SYS CONFLICT	<i>* The PARAMETER 'SHAFT SYSTEM' is set to a Tapehead (1) but a Position Encoder has been detected *</i>	Standard
119	PSE WRONG DIRECT	<i>* The lift tried to go up or go down when the TERMINAL RESET was on - CHECK - TOP and BOTTOM LIMITS *</i>	Standard
120	PSE NO STOP MESS		
133	PARAMETERS RESET	<i>* The Program Parameters have been reset to the factory default settings from the MMI *</i>	Standard

## 8 System Monitor

The "System Monitor" screens give more detailed information regarding the operational state of the Qube microprocessor system.

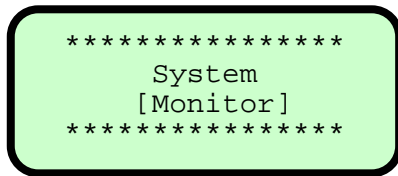

From the "System Monitor" screen press E to access the sub-menu options as shown below Press ↑ or ↓ to view each screen. As with all the menu sections, the first sub-menu screen will be shown again after the last sub-menu screen.

In this menu it is possible to check the status of the following;

- Floor Maps showing allowed & secured floors/individual calls, registered car & landing calls
- QMB motherboard & I/O block input status
- QMB motherboard & I/O block output status
- Front & rear door flag status
- PSE flag status
- CAN network status

## Operating Instructions

**8.1 Floor Maps**

The floor maps show which calls are allowed (denoted by "-") or secured (denoted by "x") by floor for both front and rear calls.

The following screens are shown for 8 floors full collective and where calls are allowed, a registered call will display "C" for a car call, "U" for up landing call and "D" for down landing call.

On the floor map screens shown below, the lift position, denoted by a flashing cursor, is shown at floor 6 on the front & rear screens, a front car call is present at floor 4, a front up landing call is present at floor 1 and a down landing call is present at floor 7.

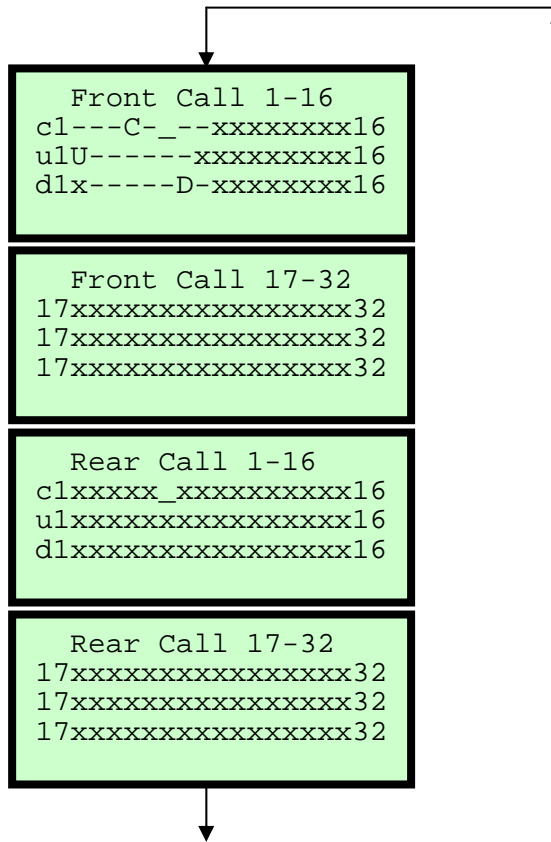

## 8.2 QMB Motherboard & I/O Block Input Status

The input status blocks show whether or not that the Qube microprocessor has correctly read and processed the system inputs.

The QMB input state screen shows the motherboard input status, where the JP6 shows IN1-IN8, JP8 shows IN9-IN16 and JP4 shows IN17-IN24. However, in each case the inputs should be read from right to left.

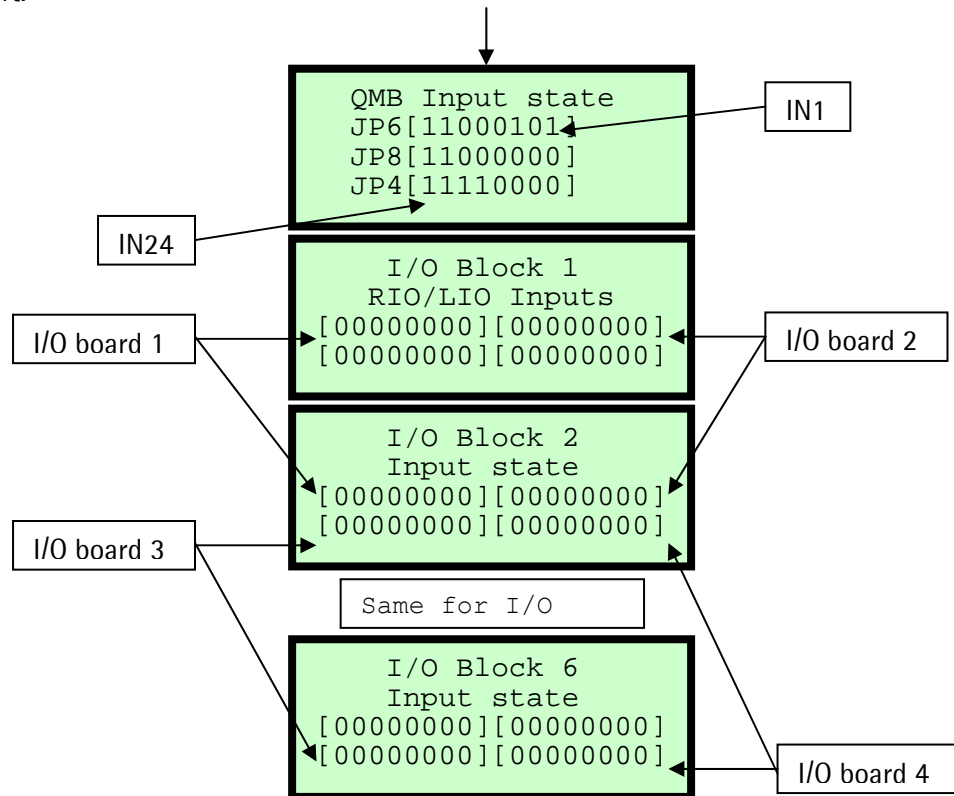

Each I/O Block screen represents the input status of each of the I/O boards attached to one of the expansion node boards, usually addressed as node 1 - 6. The RIO/LIO car interface is always addressed as node 1, other functions have different addresses (see RIO Interface section for details).

On the I/O Block screen, the boards are represented as shown above, and as with the motherboard screen, the inputs for each board block should be read from right to left.

When the input status screens are used in conjunction with the LED's mounted adjacent to each of the input terminal, it is possible to determine whether the software is correctly responding to the hardware state.

### 8.3 QMB Motherboard & I/O Block Output Status

The output status blocks show which outputs have been switched ON by the Qube microprocessor.

The QMB output state screen shows the motherboard output status, where the JP2/JP3 shows QK1-QK8, JP5 shows QK9-QK16 and JP7 shows QK17-QK24. However, in each case the outputs should be read from right to left.

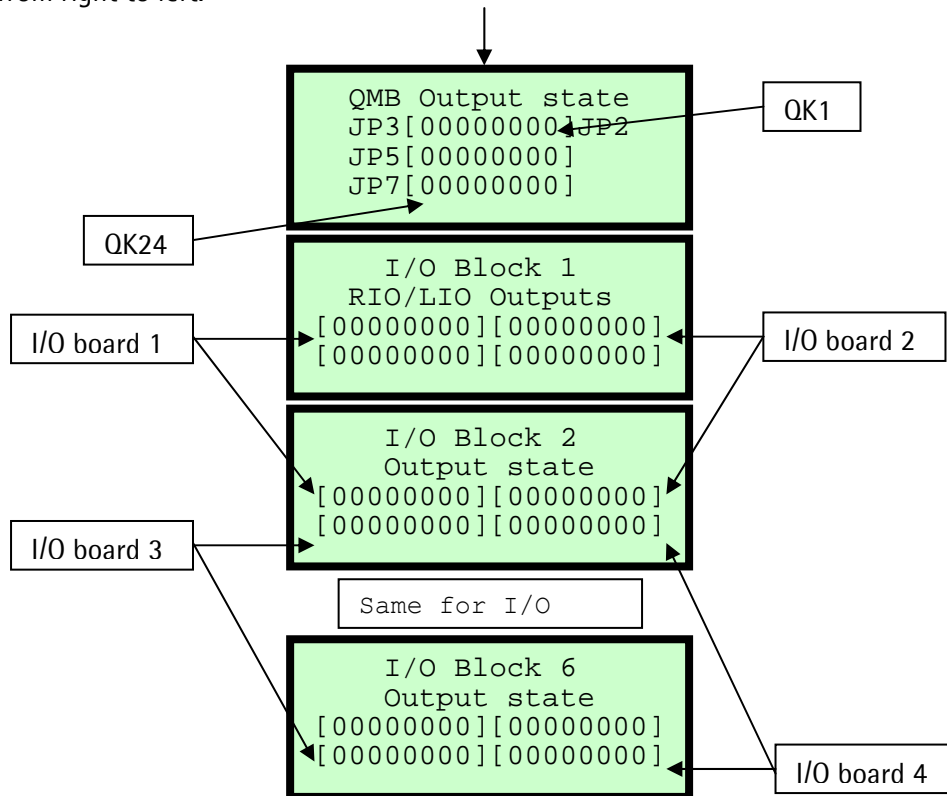

Each I/O Block screen represents the output status of each of the I/O boards attached to one of the expansion node boards, usually addressed as node 1 - 6. The RIO/LIO car interface is always addressed as node 1, other functions have different addresses (see RIO Interface section for details).

On the I/O Block screen, the boards are represented as shown above, and as with the motherboard screen, the outputs for each board block should be read from right to left.

When the output status screens are used in conjunction with the LED's mounted adjacent to each of the output relays, it is possible to determine whether the output hardware is correctly responding to the software commands.



## 8.4 Door Flag Status

The door status screens confirm which of the door related inputs, outputs & parameters have been activated.

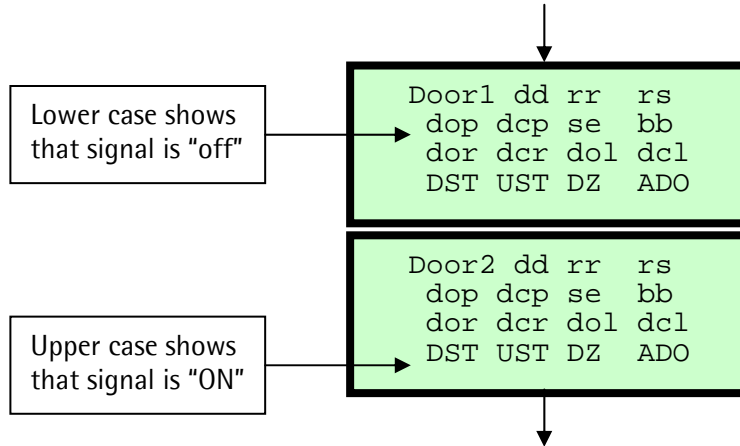

Door 1 screen shows front door status & Door 2 screen shows rear door status, although some of the signals are common to both doors.

Signal	Description
dd/DD	Door Disable Parameter in Engineers Tools menu
rr/RR	Retiring Ramp Output
rs/RS	Ramp Switch Input
dop/DOP	Door Open Push Input
dcp/DCP	Door Close Push Input
se/SE	Safety Edge Input
bb/BB	Broken Beam Input
dor/DOR	Open Door Output
dcr/DCR	Close Door Output
dol/DOL	Door Open Limit Input
dcl/DCL	Door Close Limit Input
dst/DST	Down Slow/Stop Input
ust/UST	Up Slow/Stop Input
dz/DZ	Door Zone Input
ado/ADO	Pre-open Doors Parameter in System Configure [Contract] menu

## 8.5 PSE Flag Status

The PSE status screen show the status of the internal positioning variables in the Qube & PSE encoder.

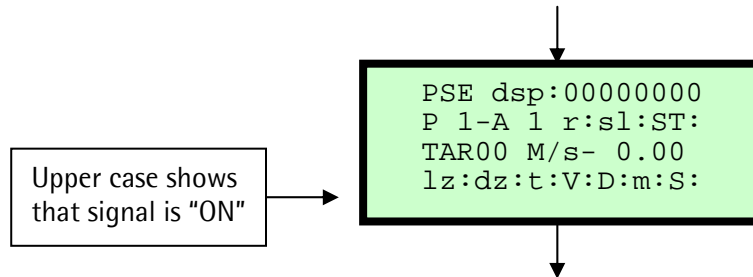

- dsp: Door speed (speed at which doors may start pre-opening) set via parameter.  
r: Reset switch (State of position reset switch).  
sl: Slowdown - used to initiate a slowdown sequence.  
st: Stop - used to initiate a controlled stop.  
lz: Level zone - used to identify the relevel zone position.  
dz: Door zone - used to identify the calculated door zone position.  
t: Terminal control - used to identify when system is in setup shaft process.  
V: DPS Valid - used to identify when system is valid i.e been passed the reset switch after power up.  
u: or d: Up or Down - used to identify the rotation of encoder.  
m: Magnet zone - used to identify when the encoder is reading the magnets at each floor.  
s: DPS Setup - used to identify if the DPS has been setup (learnt).

Further information on the PSE system can be found in the Digital Position System Installation Manual.

## 8.6 CAN Network Status

The Network Status screens show the status of the CAN networks on the Qube motherboard.

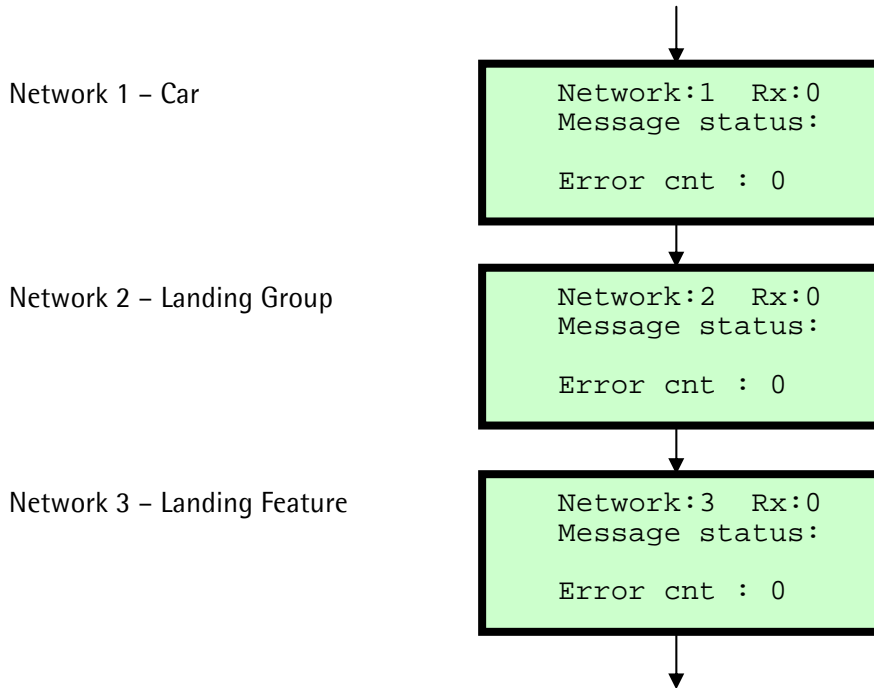

Displays Rx status of each network. When working correctly Rx is changing between 0 and 1 and the error count is 0.

The Message status: displays information regarding the operation of the CANbus for the selected network, where typical messages are - Buss Off, Ewrn 96, RxOk Int, Tx Ok, Stuff Err, Form Err, ACK Err, Bit1 Err, Bit0 Boff, Bit0 Bon, CRC Err, Msg Lost.

## Operating Instructions

**9 Engineers Tools**

The Engineers Tools menu contains options to assist with commissioning and fault finding.

**9.1 Using Engineers Tool Options**

```
*****  
Engineers  
[Tools]  
*****
```

From the "Engineers [Tools]" screen press **E** to access the sub-menu options as shown below Press **↑** or **↓** to view each screen.

Press **↑** or **↓** to view options.

Bottom line displays the option.

```
*****  
Engineers  
Menu  
[Prep to test]
```

To select the option, press **E**

```
PREP TO TEST:OFF  
Pos:8 Calls:0  
Doors : Closing  
Stopped M/s 0.00
```

To enable the option, press **E**

```
PREP TO TEST:ON  
Pos:8 Calls:0  
Doors : Closing  
Stopped M/s 0.00
```

To exit the option, press **←**

```
*****  
Engineers  
Menu  
[Prep to test]
```

Press **↑** to view next option.

```
*****  
Engineers  
Menu  
[ Door Disable ]
```

In each case, select the tool required and then press the E button to toggle ON/OFF.

**9.2 Engineers Tools Descriptions**

Tool Option	Function
Prep to Test	Disables landing calls to prevent further use of the lift prior to switching to Test / EMOP control. All outstanding landing calls will be cancelled, or transferred where the lift is part of a group of 2 or more lifts. Car calls operate normally until the last call is answered, then the doors will close allowing the engineer to take control of the lift.
Door Disable	Prevents the doors opening after answering a call entered from the controller. This is useful for tuning of the drive system without allowing passengers to use the lift. In this mode, landing calls are disabled and the lift is removed from group operation but car calls can still be entered from the controller or the car.
Over travel test	Allows the lift to be driven beyond the terminal floor stopping switches in order to test the functionality of the final limit switches. Only when operating on EMOP control.
Auto run lift	Automatically runs the lift for a set number of calls as defined by the "HOT TEST x 10" in the System Configure [Contract] menu.
Disable Direct To Floor	Disables floor correction operation by cutting off the floor correction switch input into the CT Unidrive.
Speech Disable	Disables the speech synthesiser during installation to prevent nuisance speech messages prior to commissioning.
WS Bypass	Disables the WS90 input to allow the lift to run in case of faulty or uncommissioned load weighing system.
WS Overload	Disables the WSOL input to allow the lift to run in case of faulty or uncommissioned load weighing system.
Test Event Logging	Allows faults to be logged when running in Test / EMOP control during installation.
Test C-Light	Allows car light control to be tested by flashing the output relay on the QMB motherboard on/off for 100 times.

In all cases, each engineers tool option will remain ON until turned off or the processor is reset via the reset button or by cycling the power to the motherboard.

**NOTE:** It is not possible to save the state of an engineers tool option.

## Operating Instructions

**10 System I/O Descriptions****10.1 Standard Input Designations****10.1.1 Traclite Motherboard**

Inputs	Ref.	Description	Plug	Terminal
1	MS	Safety Circuit Feed	JP6	3
2	MS8	Normal control	JP6	4
3	MS6	Inspection control	JP6	5
4	MS10	EMOP control	JP6	6
5	EUP	EMOP up push	JP6	7
6	EDN	EMOP down push	JP6	8
7	GS1	Car gate contact	JP6	9
8	GS2	Landing gate contacts	JP6	10
9	SI1	Spare input 1	JP8	1
10	SI2	Spare input 2	JP8	2
11	SI3	Spare input 3	JP8	3
12	SI4	Spare input 4	JP8	4
13	BKS	Brake switch/relay (K3) monitor	JP8	5
14	K2	Motor running	JP8	6
15	K4	Start allowed	JP8	7
16	DOK	Drive OK	JP8	8
17	SS1	Fire alarm (Normally closed contact)	JP4	1
18	SS2	Fire switch	JP4	2
19	SS3	Top floor reset/Mid-shaft reset	JP4	3
20	SS4	Bottom floor reset/Terminal floor	JP4	4
21	DST	Down slowing/stopping signal	JP4	5
22	UST	Up slowing/stopping signal	JP4	6
23	GLBP	Gate-lock by-pass	JP4	7
24	DZ	Door zone	JP4	8

Spare Inputs 1-4 are commonly used for:-

- SI1- Brake wear switch
- SI2- Terminal floor limit monitor
- SI3- Main floor fire sensor (alternate fire floor operation)
- SI4- any other function

Shaft Signals 1-4 (24Vdc) are commonly used for:-

- SS1- Fire alarm contact
- SS2- Firemans switch
- SS3- Position reset (PSE) or Top floor reset (Tapehead)
- SS4- Terminal floor switch (PSE) or Bottom floor reset (Tapehead)

## Operating Instructions

**10.1.2 24-way CAN I/O Board**

Inputs	Key	Description	Plug	Terminal
IP1	DOL	Door open limit	J5	9
IP2	DCL	Door close limit	J5	8
IP3	DOP	Door open push	J5	7
IP4	DCP	Door close push	J5	6
IP5	SE	Safety edge/Light-screen	J5	4
IP6	SSIP	Car preference/Goods control	J5	3
IP7	WS90	90% load switch (Landing call bypass)	J5	2
IP8	WSOL	110% load switch (Car overload)	J5	1
IP9	TUP	Inspection up push	J3	9
IP10	TDN	Inspection down push	J3	8
IP11	DTO	Door test open switch	J3	7
IP12	DTC	Door test close switch	J3	6
IP13	CP1	Call push 1	J3	4
IP14	CP2	Call push 2	J3	3
IP15	CP3	Call push 3	J3	2
IP16	CP4	Call push 4	J3	1
IP17	CP5	Call push 5	J2	9
IP18	CP6	Call push 6	J2	8
IP19	CP7	Call push 7	J2	7
IP20	CP8	Call push 8	J2	6
IP21	CP9	Call push 9	J2	4
IP22	CP10	Call push 10	J2	3
IP23	CP11	Call push 11	J2	2
IP24	CP12	Call push 12	J2	1

**10.1.3 8-way Extension I/O Board**

IP25	CP13	Call push 13	J2	9
IP26	CP14	Call push 14	J2	8
IP27	CP15	Call push 15	J2	7
IP28	CP16	Call push 16	J2	6
IP29	CP17	Call push 17	J2	4
IP30	CP18	Call push 18	J2	3
IP31	CP19	Call push 19	J2	2
IP32	CP20	Call push 20	J2	1

## 10.2 Input Descriptions

### 10.2.1 Traclite Motherboard Block 1 (IP1-8 on JP6 connector)

#### IP1 - SAFETY CIRCUIT FEED

##### IP2 - NORM (Normal control)

The test switch in the car-top control and the emergency electrical operation switch in the controller must be in the NORMAL position and the primary safety circuit must be complete for the NORM input to be present.

When this input is ON, the lift may operate in normal or emergency electrical operation mode depending on the state of EMERG input.

Car-top test functions are disabled.

Loss of this input signifies that one of the following conditions is true,

Car-top test switch is in the TEST position.

EMOP test switch is in the TEST position.

Primary Safety circuit is broken.

##### IP3 - TEST (Car-top test control)

The test switch in the car-top control must be in the TEST position and the primary safety circuit must be intact for the TEST input to be present.

When this input is ON, car top test functions are activated as follows,

Allow movement of the lift in response to the test UP/DN/FST push buttons.

Allow movement of the doors in response to the door test switch.

Control any auxiliary devices related to a demand from 1)&2) above.

Loss of this input signifies that either,

The test switch in the car top control is in the NORMAL position or,

The primary safety circuit is broken.

Note: Loss of input NORM on the host controller and input TEST on the car top interface signifies a primary safety circuit failure.

##### IP4 - EMOP (Emergency Electrical Operation)

The test switch in the car-top control must be in the NORMAL position and the emergency electrical operation switch in the controller must be in the TEST position and the primary safety circuit must be complete for the EMERG input to be present.

When this input is ON it is possible to drive the lift using the up/down push-buttons on the controller providing the gate-lock inputs 1&2 are both ON.

Emergency electrical operation is also known as panel test and in this mode it is possible to drive the lift without the car top I/O unit being present.

Loss of this input signifies that one of the following conditions is true,

Car-top test switch is in the TEST position.

Emergency electrical operation switch is in the NORMAL position

Primary Safety circuit is broken.



**IP5 - EMOP UP (Emergency Operation Up Push)**

When the control system is in emergency electrical operation mode and the emergency operation up push button is pressed, EMOP\_UP input is active and power is fed to the gate lock circuit. The control will then energise the necessary outputs to allow the lift to move in the up direction at test speed providing the gate lock circuit is made.

**IP6 - EMOP DN (Emergency Operation Down Push)**

When the control system is in emergency electrical operation mode and the emergency operation up push button is pressed, EMOP\_DN input is active and power is fed to the gate lock circuit. The control will then energise the necessary outputs to allow the lift to move in the down direction at test speed providing the gate lock circuit is made.

**IP7 - GATE LOCK 1 (Car gate contact)**

Monitors the state of the car gate contact, this signal must be present before a normal run is allowed. Loss of this signal during travel will cause an emergency stop of the lift.

The gate lock function check ensures that this signal is lost when the doors have opened fully. If the signal is still present with the doors fully open, then the lift will be prevented from further operation.

**IP8 - GATE LOCK 2 (Landing Gate Contacts)**

Monitors the state of the landing gate contacts. Operation as GL1 above.

Note: The gate lock circuit may be by-passed during pre-opening of the doors. If the doors reach the fully open position before the stopping sequence has completed the DOL signal will be lost before the gate lock signals (causing the gate lock function check to fail). In this case the software must perform an Emergency stop, ensuring that all movement controls are released immediately. The gate lock function check may then be re-validated.

Note: The gate lock circuit may be by-passed during pre-opening of the doors. If the doors reach the fully open position before the stopping sequence has completed the DOL signal will be lost before the gate lock signals (causing the gate lock function check to fail). In this case the software must perform an Emergency stop, ensuring that all movement controls are released immediately. The gate lock function check may then be re-validated.

**10.2.2 Traclite Motherboard Block 2 (IP9-16 on JP8 connector)****IP9/10/11/12 – SPARE INPUTS (110VAC)**

These inputs can be designated as required to suit a specific controller application. The functions shown below can be utilised as required and are set in the controller software prior to delivery.

- BRAKE WEAR SWITCH
- TERMINAL LIMIT MONITOR
- MAIN FLOOR FIRE SENSOR

**IP13 – BRAKE SWITCH & CONTACTOR MONITOR**

Checks the status of the brake switch (if fitted) and the brake contactor K3. If the brake input does not switch ON within a few seconds of the start demand the current journey will be aborted.

**IP14 – MAIN CONTACTOR (Lift Running)**

Monitors the lift running contactors indicate that the lift is moving. Failure of this signal to operate, within an adjustable time of a start command, will result in a start failure fault being recorded in the event logger.

The lift doors will cycle before a further attempt to start is made.

Loss of this signal during travel will cause an emergency stop.

A variable, accessible from the keypad will allow the customer to set the number of restarts before the lift is shutdown.

**IP15 – START ALLOWED (Checks contactor release & Supply health)**

This input monitors all the relays, contactors and other devices that should release after each journey and the state of the main supply monitoring device (PFRR).

The input should be present before initialisation, but will be lost immediately after initialisation of each journey.

If the input remains in the off state after the lift has stopped, further use of the lift will be prohibited and a fault will be recorded in the event logger.

**IP16 – DRIVE OK**

This input monitors the Fault/Alarm contact from the motor-drive system. This contact should be in the closed position if the drive is on-line and opens if a drive fault occurs.

If this contact is open then microprocessor should try to reset the drive using the DRES output if a demand is present.

If a drive fault occurs during a travel of the lift then the an Emergency stop will occur.

**10.2.3 Traclite Motherboard Block 3 (IP17-24 on JP4 connector)****IP17/18/19/20 – SPARE INPUTS (24VDC)**

These inputs can be designated as required to suit a specific controller application. The functions shown below can be utilised as required and are set in the controller software prior to delivery.

- **FAM (Fire Alarm)**
- **FSI (Fire Recall Switch )**  
This signal is activated by operation of the fire recall switch mounted at the main entrance floor of the building, adjacent to the lift entrance. When activated the lift will return to the fire recall level.
- **MID-SHAFT RESET**
- **TERMINAL FLOOR SWITCH**
- **SU1/SD1 (Up/Down Slowing Signal @ HS1)**  
Monitors the SU1/SD1 stepping signal in the shaft when running on high speed 1. The internal position counter of the processor is incremented or decremented, depending on the direction of the lift, on the leading edge of the signal, if a call is present at the next floor the lift will slow down on the trailing edge of the signal.  
If the lift slows or is already slowing from a higher speed this signal will cancel the call and allow operation of any annunciator devices at the landing or in the lift car.
- **TFR (TOP FLOOR RESET)**  
Monitors the state of the top floor reset switch. When the input is on, the reset switch is made and the microprocessor will synchronise its internal position counter to the top floor set in the system.  
The lift uses the position of the top floor reset limit as its slowdown point during an upwards terminal floor dive operation to allow a controlled stop at the top floor level.
- **BFR (BOTTOM FLOOR RESET)**  
Monitors the state of the bottom floor reset switch. When the input is on, the reset switch is made and the microprocessor will synchronise its internal position counter to the bottom floor set in the system.  
The lift uses the position of the bottom floor reset limit as its slowdown point during a downwards terminal floor dive operation to allow a controlled stop at the bottom floor level.  
Note: The reset limit signals are also used as direction checking devices, please refer to description later in this manual.

**IP21 - DOWN STOP (Down Stopping Signal)**

This input signals the microprocessor to begin the stopping sequence in the down direction, after slowing at the appropriate point in the shaft. The floor levelling accuracy in the down direction is set using this input in conjunction with the levelling speed of the drive system.

DST is also used in conjunction with input DZ for door zone verification.

**IP22 - UP STOP (Up Stopping Signal)**

This input signals the microprocessor to begin the stopping sequence in the up direction, after slowing at the appropriate point in the shaft. The floor levelling accuracy in the up direction is set using this input in conjunction with the levelling speed of the drive system.

UST is also used in conjunction with input DZ for door zone verification.

**IP23 - RE-LEVELLING ENABLE (Advance Door Open/Re-levelling Enable)**

When this input is present it means that the safety circuit by-pass module (HSP-01-E) is satisfied that the door zone switching sequence has been successfully achieved during the previous operation of the lift.

Unless this input is present, the gate lock by-pass contact (A21/A25) will not operate.

This means that any operation that allows movement of the lift with open doors, such as advance door opening or re-levelling, will be disabled.

**IP24 - DZ (DOOR ZONE)**

When this input is present, in conjunction with UST or DST, the control board can begin the door open sequence prior to the lift stopping at the target floor providing that the safety circuit by-pass module has verified the door zone switching sequence.

This signal must also be present, in conjunction with UST or DST, in order for re-levelling operation to occur.

Note: The signals DST/UST/DZ must be proven to have released during the each travel of the lift.

An error in operation of one of these signals means that and any operation that allows movement of the lift with open doors, such as advance door opening or re-levelling, will be disabled.

**10.2.4 24-way CAN I/O Board & Extension****IP1 - DOOR OPEN LIMIT**

Monitors the state of the door open limit. This input should be off when the doors are in the fully open position and on at all other times. If this signal remains off with the doors fully closed and the gate lock signals present or the doors are fully open and the gate lock signals are still present the gate lock function check ensures that the lift is prevented from further operation.

**IP2 - DOOR CLOSE LIMIT**

Monitors the state of the door close limit. This input should be off when the doors are in the fully closed position and on at all other times. The lift will be prevented from starting if this signal is not lost when the doors have closed. Once the lift has started the signal may be switched on again, as is the case when a stall condition is applied to the door operator during lift travel.

**IP3 - DOOR OPEN PUSH**

This input is operated by the door open push situated within the lift car. When the door open push is pressed the doors will always attempt to open as long as the lift is stopped and is within a valid door zone.

**IP4 - DOOR CLOSE PUSH**

This input is operated by the door close push situated within the lift car. When the door close push is pressed the doors will always attempt to close immediately as long as the door open push is not operated or the doors are not being obstructed.

**IP5 - SAFETY EDGE/LIGHT SCREEN**

This input is operated by the safety detector situated on the car door edge. When an obstruction is detected by the safety edge the doors will attempt to re-open if they are closing.  
This input is only active as long as the lift is stopped within a valid door zone.

**IP6 - GOODS/SPECIAL SERVICE**

Operated by keyswitch in the lift car. When this input is activated all landing calls are cancelled and the car will park at a floor level with open doors and only respond to car calls. The doors can only be closed by pressing and holding a car call push until the doors have fully closed and the lift has started. When the first car call in the direction of travel has been answered the doors will open automatically and cancel all remaining calls.

**FIRE SERVICE (Fire Recall Switch )**

This signal is activated by operation of the fire recall switch mounted at the main entrance floor of the building, adjacent to the lift entrance. When activated the lift will return to the fire recall level.

**IP7 - WS90 (By-Pass load switch)**

Detects the fully loaded condition of lift. When this input is set the car will remain at a landing with the doors parked in the open position until a car call is entered. Once moving the lift will by-pass all landing calls, stopping only for the next car call in the direction of travel. When the lift is at the main floor and operating on up peak mode the doors will automatically close once this input is activated.

**IP8 - WSOL (Car overload switch)**

Detects the overloaded (110% of contract load) condition of the lift. When this input is set the car will remain at a landing with the doors parked in the open position until the load is reduced. During this time an indicator in the lift car will be illuminated, a buzzer will sound and if a speech synthesiser is fitted to the lift, an announcement advising a reduction of the lift load will be made.

**IP9 - TEST UP (Car-top Test Up Push)**

When the control system is in car top test mode and the test up push button is pressed, TUP input is active and power is fed to the gate lock circuit.

The control will then energise the necessary outputs to allow the lift to move in the up direction at test speed providing the gate lock circuit is made.

**IP10 - TEST DOWN (Car-top Test Down Push)**

When the control system is in car top test mode and the test down push button is pressed, TDN input is active and power is fed to the gate lock circuit.

The control will then energise the necessary outputs to allow the lift to move in the down direction at test speed providing the gate lock circuit is made.

**IP11 - DOOR TEST OPEN (Car-top Door Open Test Switch)**

When activated, gives the DOOR OPEN output to command the doors to open. Only operates when in Car-top test mode.

**IP12 - DOOR TEST CLOSE (Car-top Door Close Test Switch)**

When activated, gives the DOOR CLOSE output to command the doors to close. Only operates when in Car-top test mode.

**IP13 to IP32 - CP1-20 Call pushes**

The call push inputs are configured to suit the number of floors and the type of call system (see section x.x for further details).

### 10.3 Standard Output Designations

#### 10.3.1 Traclite Motherboard

Outputs	Description	Plug	Terminal
QK1	Travel Up	JP2	8 & 10 *
QK2	Travel Down	JP2	8 & 9 *
QK3	spare	JP2	5 & 6
QK4	Cabinet Fan	JP2	3 & 4
<i>QK1 - QK4 are volt free n/o contacts</i>			
QK5	Alarm Filter (n/c)	JP2	1 & JP3/10
QK6	Gate-lock Bypass	JP3	7 & 9
QK7	Up Demand	JP3	6 & 2 **
QK8	Down Demand	JP3	3 & 5 **
<i>QK5 - QK8 are volt free change over contacts</i>			
QK9	Speed Ref A	JP5	10
QK10	Speed Ref B	JP5	9
QK11	Speed Ref C	JP5	8
QK12	Drive Reset	JP5	7
<i>QK9 - QK12 fed from common connection</i>			
QK13	Free Output	JP5	5
QK14	Free Output	JP5	4
QK15	Floor Zone A	JP5	3
QK16	Floor Zone B	JP5	2
<i>QK13 - QK16 fed from common connection</i>			
QK17	Open Door	JP7	10
QK18	Close Door	JP7	9
QK19	Nudge Door	JP7	8
QK20	Ramp/ZLR	JP7	7
<i>QK17 - QK20 fed from common connection</i>			
QK21	Rear Open Door	JP7	5
QK22	Rear Close Door	JP7	4
QK23	Rear Nudge Door	JP7	3
QK24	Rear Ramp/ZLR	JP7	2
<i>QK21 - QK24 fed from common connection</i>			

\* QK1/QK2 outputs are electrically interlocked on the circuit board to ensure that the UP/DN limit feeds are not enabled simultaneously.

\*\* QK7/QK8 outputs are electrically interlocked on the terminal rail to ensure that the UP/DN commands to the inverter cannot be given simultaneously.

**10.3.2 24-way CAN I/O Board**

Inputs	Ref.	Description	Plug	Terminal
OP1	POA	Position bit 0	J9	9
OP2	POB	Position bit 1	J9	8
OP3	POC	Position bit 2	J9	7
OP4	POD	Position bit 3	J9	6
OP5	IU	Up direction indicator	J9	4
OP6	ID	Down direction indicator	J9	3
OP7	CBZR	Car call acknowledge buzzer	J9	2
OP8	COLI	Car overloaded indicator	J9	1
OP9	LOSI	Lift out of service indicator	J8	9
OP10	FSI	Firemans control indicator	J8	8
OP11	HLU	Up hall lantern	J8	7
OP12	HLD	Down hall lantern	J8	6
OP13	CA1	Call indicator 1	J8	4
OP14	CA2	Call indicator 2	J8	3
OP15	CA3	Call indicator 3	J8	2
OP16	CA4	Call indicator 4	J8	1
OP17	CA5	Call indicator 5	J7	9
OP18	CA6	Call indicator 6	J7	8
OP19	CA7	Call indicator 7	J7	7
OP20	CA8	Call indicator 8	J7	6
OP21	CA9	Call indicator 9	J7	4
OP22	CA10	Call indicator 10	J7	3
OP23	CA11	Call indicator 11	J7	2
OP24	CA12	Call indicator 12	J7	1

**10.3.3 8-way Extension I/O Board**

OP25	CA13	Call indicator 13	J4	9
OP26	CA14	Call indicator 14	J4	8
OP27	CA15	Call indicator 15	J4	7
OP28	CA16	Call indicator 16	J4	6
OP29	CA17	Call indicator 17	J4	4
OP30	CA18	Call indicator 18	J4	3
OP31	CA19	Call indicator 19	J4	2
OP32	CA20	Call indicator 20	J4	1



## 10.4 Output Descriptions

### 10.4.1 Traclite Motherboard Block 1 (QK1-8 on JP2 & JP3)

#### QK1 & QK7 - TRAVEL UP (Up Demand)

Initiates an UP travel in response to a call above the lift. The gate lock inputs must be present and all safety checks completed before the up demand relay is energised.

UR must stay on for a short time after the speed outputs are released to allow the stopping action to be controlled by the Unidrive inverter.

#### QK2 & QK8 - TRAVEL DOWN (Down Demand)

Initiates a DOWN travel in response to a call below the lift. The gate lock inputs must be present and all safety checks completed before the down demand relay is energised.

DR must stay on for a short time after the speed outputs are released to allow the stopping action to be controlled by the Unidrive inverter.

Note: QK1/2 control the main contactors K1/K2 and enable the terminal floor limits for the correct direction of travel whereas QK7/8 provide the direction demand to the inverter.

Both QK1/2 and QK7/8 are electrically interlocked pairs of contacts to ensure that both directions cannot be selected at the same time due to a malfunction of an output relay.

#### QK3 - spare

#### QK4 - FAN (Cabinet ventilation fan)

The fan control operates each time the lift runs and remains active for 5 minutes after completion of the last journey.

#### QK5 - Alarm Filter

The alarm filter only operates in normal control and is active under the following conditions;

- i) the lift is running and the doors are opening at the next landing stop
- ii) when the lift is stopped in a door zone with the door fully open.

#### QK6 - GATE LOCK BY-PASS

This output is energised only when the lift is in automatic mode and allowed to move with the doors open, such as during advance door opening or re-levelling. If any error is detected in the operation of the door zone switches or safety circuit by-pass module, the output will be disabled.

**10.4.2 Traclite Motherboard Block 2 (QK9-16 on JP5)****QK9/10/11 - SPEED REFA/B/C (Traction Machines with Inverter only)**

The speed reference outputs select the target speed for the inverter by setting a binary code as shown in the table below.

Speed Function	Inverter Speed	Unidrive Parameter #	Speed Ref.A (QK9)	Speed Ref.B (QK10)	Speed Ref.C (QK11)
Zero	V0	#1.21	0	0	0
Inspection Lo	V1	#1.22 (18.11)	1	0	0
Emerg.rescue	V2	#1.23 (18.12)	0	1	0
Re-levelling	V3	#1.24 (18.13)	1	1	0
Levelling	V4	#1.25 (18.14)	0	0	1
High Speed 1	V5	#1.26 (18.15)	1	0	1
High Speed 2	V6	#1.27 (18.16)	0	1	1
High Speed 3	V7	#1.28 (18.17)	1	1	1

Unidrive parameter numbers in brackets are valid when additional "Elevator Solution Module" is fitted for high spec. Closed loop vector and Servo mode applications.

**QK12 - DRIVE RESET**

This output pulses to reset the Unidrive in the event of the "DRIVE OK" input (IP16) being lost.

**QK13/14 - Free outputs**

These outputs can be designated as required to suit a specific controller application. The functions shown below can be utilised as required and are set in the controller software prior to delivery.

- Floor Correction Switch Enable
- SMU threshold
- Landing Network Disconnect

**QK15 - Floor Zone A****QK16 - Floor Zone B**

**10.4.3 Traclite Motherboard Block 3 (QK17-24 on JP7)****QK17 - OPEN DOOR (Door Open Control)**

Provides the door open signal to the door operator, either directly to a door regulator or via a contactor.

In automatic mode DOC will energise to open the lift doors providing the door open limit is not broken and the lift is stopping or stopped within a valid door zone.

In car top test mode DOC will energise to open the lift doors when the door test open switch is operated, irrespective of the state of the door open limit.

**QK18 - CLOSE DOOR (Door Close Control)**

Provides the door close signal to the door operator, either directly to a door regulator or via a contactor.

In automatic mode DCC will energise to close the lift doors providing the door close limit is not broken and all other safety conditions are met.

In car top test mode DCC will energise to close the lift doors when the door test close switch is operated, irrespective of the state of the door close limit.

**QK19 - NUDGE DOOR (Door Nudging Control)**

Provides the door nudging signal to the door operator, either directly to a door regulator or via a contactor.

Required to forcibly close the doors, at a reduced torque and speed, under emergency conditions or when the lift is held up for an unreasonable time period by the user. When nudging is active the safety edge input is ignored but the door open push input remains active.

**QK20 - RAMP (Ramp Contactor Control)**

Controls the retiring ramp solenoid when used with Express/Bennie AC doors or manual gates.

**QK21/2/3/4 – Repeat of QK17/18/19/20 for rear door controls**

**10.4.4 24-way CAN I/O Board & Extension**

OP1	POA	Position bits 0	)	
OP2	POB	Position bits 1	)	These outputs can be configured to give a binary or gray code output to indicate the position of the lift
OP3	POC	Position bits 2	)	
OP4	POD	Position bits 3	)	
OP5	IU	Up direction		
OP6	ID	Down direction		
OP7	CBZR	Car call registration buzzer		
OP8	COLI	Car overloaded		
OP9	LOSI	Lift out of service		
OP10	FSI	Fire service		
OP11	HLU	Up hall lantern		
OP12	HLD	Down hall lantern		

The outputs OP1-OP12 can be used to drive individual indicators or a third party indicator encoder board (e.g. Liftstore, Stentorgate, Schaeffer, etc..).

**OP13 to OP32 - CA1-20 Call acceptance indicators**

The call acceptance indicators outputs are configured to suit the number of floors and the type of call system (see section x.x for further details).

## Operating Instructions

**10.5 Call Push Interface**

The basic Traclite controller has 20 call inputs & 20 call outputs available for car and landing calls. Whereas car calls are always connected directly to the controller terminal rail and into the call push interface, landing calls may be connected directly to the controller or alternatively via the landing CAN bus.

When the landing calls are connected via the optional landing CAN network, all the call I/O is configured as car calls giving a floor service capability of 20 floors, in any call system mode.

However, when landing calls are connected directly to the controller, the floor service capability is reduced as follows;

Call System	Max floors
Full Collective	7
Down Collective	10
Non-selective collective	10
FAPB	10

Refer to the following tables for call push & indicator connections, where

- C1,C2 etc... = Car call
- L1U,L2U etc... = Landing Up call
- L2D,L3D etc... = Landing Down call
- L1,L2 etc... = Landing call

Call acceptance indicator connections follow the same structure as the call push inputs shown above.

**10.5.1 Call Connection Tables**

Full Collective Call Connection Table

Call Input	2 floors	3 floors	4 floors	5 floors	6 floors	7 floors
CP1	C1	C1	C1	C1	C1	C1
CP2	C2	C2	C2	C2	C2	C2
CP3	L1U	C3	C3	C3	C3	C3
CP4	L2D	L1U	C4	C4	C4	C4
CP5	-	L2U	L1U	C5	C5	C5
CP6	-	L2D	L2U	L1U	C6	C6
CP7	-	L3D	L3U	L2U	L1U	C7
CP8	-	-	L2D	L3U	L2U	L1U
CP9	-	-	L3D	L4U	L3U	L2U
CP10	-	-	L4D	L2D	L4U	L3U
CP11	-	-	-	L3D	L5U	L4U
CP12	-	-	-	L4D	L2D	L5U
CP13	-	-	-	L5D	L3D	L6U
CP14	-	-	-	-	L4D	L2D
CP15	-	-	-	-	L5D	L3D
CP16	-	-	-	-	L6D	L4D
CP17	-	-	-	-	-	L5D
CP18	-	-	-	-	-	L6D
CP19	-	-	-	-	-	L7D
CP20	-	-	-	-	-	-

subject to change without notice!



Operating Instructions

Down Collective Call Connection Table

Call Input	2 floors	3 floors	4 floors	5 floors	6 floors	7 floors	8 floors	9 floors	10 floors
CP1	C1	C1	C1	C1	C1	C1	C1	C1	C1
CP2	C2	C2	C2	C2	C2	C2	C2	C2	C2
CP3	L1U	C3	C3	C3	C3	C3	C3	C3	C3
CP4	L2D	L1U	C4	C4	C4	C4	C4	C4	C4
CP5	-	L2D	L1U	C5	C5	C5	C5	C5	C5
CP6	-	L3D	L2D	L1U	C6	C6	C6	C6	C6
CP7	-	-	L3D	L2D	L1U	C7	C7	C7	C7
CP8	-	-	L4D	L3D	L2D	L1U	C8	C8	C8
CP9	-	-	-	L4D	L3D	L2D	L1U	C9	C9
CP10	-	-	-	L5D	L4D	L3D	L2D	L1U	C10
CP11	-	-	-	-	L5D	L4D	L3D	L2D	L1U
CP12	-	-	-	-	L6D	L5D	L4D	L3D	L2D
CP13	-	-	-	-	-	L6D	L5D	L4D	L3D
CP14	-	-	-	-	-	L7D	L6D	L5D	L4D
CP15	-	-	-	-	-	-	L7D	L6D	L5D
CP16	-	-	-	-	-	-	L8D	L7D	L6D
CP17	-	-	-	-	-	-	-	L8D	L7D
CP18	-	-	-	-	-	-	-	L9D	L8D
CP19	-	-	-	-	-	-	-	-	L9D
CP20	-	-	-	-	-	-	-	-	L10D

Non-selective Collective/FAPB Call Connection Table

Call Input	2 floors	3 floors	4 floors	5 floors	6 floors	7 floors	8 floors	9 floors	10 floors
CP1	C1	C1	C1	C1	C1	C1	C1	C1	C1
CP2	C2	C2	C2	C2	C2	C2	C2	C2	C2
CP3	L1	C3	C3	C3	C3	C3	C3	C3	C3
CP4	L2	L1	C4	C4	C4	C4	C4	C4	C4
CP5	-	L2	L1	C5	C5	C5	C5	C5	C5
CP6	-	L3	L2	L1	C6	C6	C6	C6	C6
CP7	-	-	L3	L2	L1	C7	C7	C7	C7
CP8	-	-	L4	L3	L2	L1	C8	C8	C8
CP9	-	-	-	L4	L3	L2	L1	C9	C9
CP10	-	-	-	L5	L4	L3	L2	L1	C10
CP11	-	-	-	-	L5	L4	L3	L2	L1
CP12	-	-	-	-	L6	L5	L4	L3	L2
CP13	-	-	-	-	-	L6	L5	L4	L3
CP14	-	-	-	-	-	L7	L6	L5	L4
CP15	-	-	-	-	-	-	L7	L6	L5
CP16	-	-	-	-	-	-	L8	L7	L6
CP17	-	-	-	-	-	-	-	L8	L7
CP18	-	-	-	-	-	-	-	L9	L8
CP19	-	-	-	-	-	-	-	-	L9
CP20	-	-	-	-	-	-	-	-	L10

subject to change without notice!



## 11 Universal Interface Board

The Universal interface board pictured here is used on the landing CAN network for landing call push & indicator connection and where required priority, security and other switch & indicator functions.

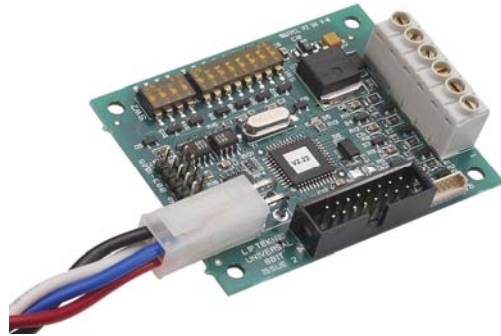

### 11.1 Switch settings for landing node

To configure the universal interface board to operate on the landing CAN network, SW1.8 must be OFF to select the Landing Interface Node function. When configured as a Landing Interface Node, SW1.1 to SW1.5 are used to select the floor level where the Universal interface is installed.

Switch functions when operating as a Landing Interface Node are as follows;

Switch	Function
SW1.1	Level Select (binary 1)
SW1.2	Level Select (binary 2)
SW1.3	Level Select (binary 4)
SW1.4	Level Select (binary 8)
SW1.5	Level Select (binary 16)
SW1.6	Always OFF
SW1.7	Protocol Select (set ON)
SW1.8	I/O Expansion Module Select (set OFF)
SW2.1	Riser Select (binary 1)
SW2.2	Riser Select (binary 2)
SW2.3	Riser Select (binary 4)
SW2.4	Always OFF

## Operating Instructions

## Floor Level &amp; Riser Number Settings for Landing Node

## Switch 1 (8-way)

SW1.1	SW1.2	SW1.3	SW1.4	SW1.5	SW1.6	SW1.7	SW1.8	Floor Level
ON	OFF	OFF	OFF	OFF	OFF	ON	OFF	Floor Level 1
OFF	ON	OFF	OFF	OFF	OFF	ON	OFF	Floor Level 2
ON	ON	OFF	OFF	OFF	OFF	ON	OFF	Floor Level 3
OFF	OFF	ON	OFF	OFF	OFF	ON	OFF	Floor Level 4
ON	OFF	ON	OFF	OFF	OFF	ON	OFF	Floor Level 5
OFF	ON	ON	OFF	OFF	OFF	ON	OFF	Floor Level 6
ON	ON	ON	OFF	OFF	OFF	ON	OFF	Floor Level 7
OFF	OFF	OFF	ON	OFF	OFF	ON	OFF	Floor Level 8
ON	OFF	OFF	ON	OFF	OFF	ON	OFF	Floor Level 9
OFF	ON	OFF	ON	OFF	OFF	ON	OFF	Floor Level 10
ON	ON	OFF	ON	OFF	OFF	ON	OFF	Floor Level 11
OFF	OFF	ON	ON	OFF	OFF	ON	OFF	Floor Level 12
ON	OFF	ON	ON	OFF	OFF	ON	OFF	Floor Level 13
OFF	ON	ON	ON	OFF	OFF	ON	OFF	Floor Level 14
ON	ON	ON	ON	OFF	OFF	ON	OFF	Floor Level 15
OFF	OFF	OFF	OFF	ON	OFF	ON	OFF	Floor Level 16

## Switch 2 (4-way)

SW2.1	SW2.2	SW2.3	SW2.4	Riser No.
OFF	OFF	OFF	Not Used	Riser 1
ON	OFF	OFF	Not Used	Riser 2
OFF	ON	OFF	Not Used	Riser 3
ON	ON	OFF	Not Used	Riser 4
OFF	OFF	ON	Not Used	Riser 5
ON	OFF	ON	Not Used	Riser 6
OFF	ON	ON	Not Used	Riser 7
ON	ON	ON	Not Used	Riser 8

Note: Switch SW1.6 always set OFF  
Switch SW1.7 set ON  
Switch SW1.8 set OFF

Switch SW2.4 always set OFF

Note: For per contract requirements please refer to contract specific drawings



## 11.2 Switch settings for 24-way I/O board

To use the universal interface in expansion I/O module mode SW1.8 is set to ON. When in this mode, SW1.1 to SW1.3 become the expansion I/O module number.

Switch functions when operating as an expansion I/O node are as follows;

Switch	Function
SW1.1	Board number Binary 1
SW1.2	Board number Binary 2
SW1.3	Board number Binary 4
SW1.4	Not Used
SW1.5	Not Used
SW1.6	Always OFF
SW1.7	Protocol Select (set ON)
SW1.8	I/O Expansion Module Select (set ON)
SW2.1	Not used
SW2.2	Not used
SW2.3	Not used
SW2.4	Not used

### Switch 1 (8-way)

SW1.1	SW1.2	SW1.3	SW1.4	SW1.5	SW1.6	SW1.7	SW1.8	I/O Module No.
OFF	OFF	OFF	OFF	OFF	OFF	ON	ON	Module 1
ON	OFF	OFF	OFF	OFF	OFF	ON	ON	Module 2
OFF	ON	OFF	OFF	OFF	OFF	ON	ON	Module 3
ON	ON	OFF	OFF	OFF	OFF	ON	ON	Module 4
OFF	OFF	ON	OFF	OFF	OFF	ON	ON	Module 5
ON	OFF	ON	OFF	OFF	OFF	ON	ON	Module 6
OFF	ON	ON	OFF	OFF	OFF	ON	ON	Module 7
ON	ON	ON	OFF	OFF	OFF	ON	ON	Module 8

### Switch 2 (4-way)

SW2.1	SW2.2	SW2.3	SW2.4	Car No.
OFF	OFF	OFF	Not Used	Car 1

Note: Switch SW1.4 set OFF  
Switch SW1.5 set OFF  
Switch SW1.6 always OFF  
Switch SW1.7 set ON  
Switch SW1.8 set ON

Switch SW2 ALL switches are OFF

Note: Expansion I/O modules are always connected to the CarCAN network so the Car number as defined by SW2 is always set to 1.

## 12 Quick start routine for Traclite with UnidriveSP drive

The sequence below should be followed to enable initial movement of the lift before the lift car is wired or to allow a rotating self-tune of the lift motor before the ropes are fitted.

- Connect mains supply and hoist motor, including brake and encoder wiring (if fitted). Ensure that any EMC guidance shown on wiring diagrams is adhered to.
- Switch on the main supply to the controller.

The LCD display on the Traclite MotherBoard (QMB) and the UnidriveSP should illuminate as shown below

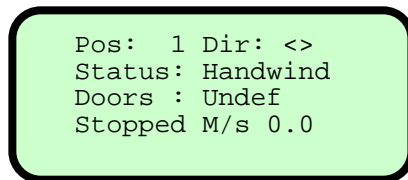

Traclite display

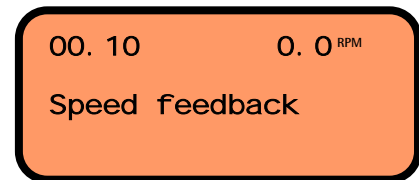

UnidriveSP display

- Now switch off the main supply at the isolator and fit any temporary links required to enable the lift to move on TEST control.

Temporary links are required for the primary safety circuit as follows;

MS – MS1	Emergency stop push
MS1 – MS2	Pit stop push/slack rope switch
MS2 – MS3	Final limits & buffer switch
MS3 – MS4	Overspeed governor switch
MS4 – MS6	Safety gear switch & car-top control
MS6 – MS6A	Test RUN push

Fitting all of the links shown above allows for progressive removal of links as safety circuit devices are connected to the controller. However, for expediency linking **MS – MS6** is also possible.

Temporary links are required for the secondary safety circuit as follows;

GS – GS1	Car gate contact
GS1 – GS2	Landing gate contacts
UTL – TUL	Test Up limit
TUL – TLE	Up terminal limit
DTL – TLE	Down terminal limit

Again, fitting all of the links shown above allows for progressive removal of links as safety circuit devices are connected to the controller.

In this case, the above is the minimum linking requirement. This is to ensure that the necessary gate lock inputs are present to allow the lift to move under TEST control and that the main relays K1/K2 do not energise until a run is requested.

## Operating Instructions

- Switch on the mains supply at the isolator, the Traclite Micro should now display as follows

```
Pos: 1 Dir: <>
Status: TEST
Doors : Open
Motion: Stopped
```

Traclite display

Note: If "Status:Handwind" or "Status:Safety-CCT", then some temporary links are still required.

If "Status:Shutdown", then there is an input conflict on the Traclite Micro, probably due to incorrect fitting of the temporary links.

- When "Status:TEST" is displayed, press and hold **E** on the MMI, the screen should now show some basic system settings as follows;

```
Lift: 1 Simplex
Bot : 1 Top : 4
Park: 1 Fire: 1
Nets: 2 SSys: 1
```

Traclite display

At this point, check that the parameter "SSys" is set to 1 or 2. This will allow movement of the lift/motor on EMOP control prior to the Position System Encoder (PSE) being fitted. If "SSys" is set to 3 or 4, refer to section 4 "Controller Configuration" on how to change this setting.

Note:

If the PSE system is being used, remember to change "SSys" back to 3 before learning the lift shaft once the PSE has been connected.

## Operating Instructions

- Ensure that the correct motor and encoder settings are programmed into the drive parameters. Once this data is entered correctly, an auto-tune should be carried out to ensure that the drive has the correct motor model data (refer to section 10 for procedure).

A static auto-tune must be performed and if possible, a rotating auto-tune should be performed to give the best possible drive performance. However, the ropes must be removed from machine before performing the rotating auto-tune.

- The lift should now run under TEST control by bridging TUP-COV for Up, or TDN-COV for Down.  
If the lift moves in the wrong direction it will be necessary to swap over two of the phases between the motor and the controller. If the lift travels in the correct direction but is slow and draws a high current, it will indicate a problem with the encoder wiring, if wiring connections seem correct try reversing the encoder signals.
- To move the lift from the car-top it will be necessary to fit and wire the car-top control unit. This will require the trailing cable to be installed and all the relevant trailing flexes to be connected back to the controller and it is strongly recommended that any available safety devices are also connected at this stage (e.g. emergency stop, safety gear switch, car gate contact etc..).  
The system also requires the DOL input to be on (indicating doors closed) before running on inspection control, link DOL-COV to achieve this prior to the door limits being connected.
- Before attempting to run the lift on high-speed ensure that all safety-circuit components are connected any working correctly and that any short-circuit connections, fitted to enable the installation to proceed, are removed.  
Where the PSE (Position Encoder) is fitted, follow the set-up instructions in the PSE manual.

## 13 Unidrive SP – Standard Lift Drive

### 13.1 Introduction

The Qube control system utilises a basic Unidrive SP inverter for geared AC machine applications which allows open loop operation for lift speeds up to 1.0m/s or closed loop operation for lift speeds up to 1.6m/s.

An enhanced Unidrive SP inverter is utilised for all gearless AC machines and high speed geared AC machines whereby lift specific software, loaded into an application module, is fitted. This software provides the necessary features required effective high speed/high quality operation. In these cases, please refer to the "UnidriveSP Elevator Solution" user guide for set-up guidance.

The Unidrive SP configured in its basic form includes the features shown below;

- Simple parameter assignment with the aid of a smart card - no keyboard or PC necessary
- Fully automatic, self-adjusting optimisation (auto-tune)
- 7 separate speeds using 3 inputs in a binary configuration
- Separately adjustable acceleration and deceleration
- Separately adjustable S-shaped transition (jerk rates) for starting and running
- Load transfer and stopping controller can be separately optimised
- Integrated brake control system with adjustable stopping profile settings
- Temperature-controlled ventilation fan speed
- Dynamically adjustable switching frequency for long IGBT lifetime
- Wide range of encoder feedback devices supported

The inverter is set-up using the following basic parameters and then adjusted to suit specific site requirements by implementing the set-up procedure that follows.

### 13.2 Assigning parameters

To set-up the UnidriveSP inverter to operate with the Qube control system, the following parameters must be changed from the factory default settings to the settings shown in the 'O.Lp' column for open loop operation or the 'C.Lp' column for closed loop operation.

This is done by entering the data via the Unidrive SP keypad, programming via CTSoft using a PC or by loading from a pre-programmed smart card (see X.X – Smart Card Programming).

If entering the data via the keypad, first ensure that #0.48 Security Status = L2.

**Note:** These settings do not apply if the UnidriveSP is fitted with the application module containing the enhanced lift software.

Operating Instructions

### 13.2.1 Basic settings for Open Loop(O.Lp) & Closed Loop(C.Lp) Operation

Note: Reference values based on 50Hz/1450rpm motor running 1.0m/s lift

Par #	Description	O.Lp Setting	C.Lp Setting	Units	Note
1.06*	Maximum reference clamp	50	1450	Hz/rpm	Max. motor freq./speed
1.14	Reference selector	Pr	Pr		Fixed speed ref's active
1.22*	Preset reference 2	15	438	Hz/rpm	Inspection lo ref.
1.23*	Preset reference 3	25	730	Hz/rpm	Inspection hi ref.
1.24*	Preset reference 4	2.5	73	Hz/rpm	Re-levelling
1.25*	Preset reference 5	2.5	73	Hz/rpm	Levelling
1.26*	Preset reference 6	50	1450	Hz/rpm	High speed 1
1.27*	Preset reference 7	50	1450	Hz/rpm	High speed 2
1.28*	Preset reference 8	50	1450	Hz/rpm	High speed 3
2.04	Ramp mode select	FASt	FASt		
2.06	S ramp enable	On	On		
2.11*	Acceleration rate 1	4		s/100 Hz	Accel (O.Lp)
			0.9	s/1000 rpm	Accel (C.Lp)
2.21*	Deceleration rate 1	4		s/100 Hz	Decel (O.Lp)
			0.9	s/1000 rpm	Decel (C.Lp)
2.22*	Deceleration rate 2	25	25	s/1000 rpm	S-ramp (run)
2.23*	Deceleration rate 3	25	25	s/1000 rpm	S-ramp (start)
3.10*	Speed controller proportional gain (Kp1)	n/a	0.15	1/rad s-1	(speed loop gain )
3.11*	Speed controller integral gain (Ki1)	n/a	1.00	1/rad	(initial settings )
3.42*	Drive encoder filter	n/a	2	ms	
4.12*	Current demand filter 1	n/a	5	ms	
7.14	T7 analog input 2 destination	10.33	10.33	para.#	Drive reset
8.21	T24 digital I/O 1 source/destination	1.47	1.47	para.#	Speed ref. C
8.22	T25 digital I/O 2 source/destination	12.40	12.40	para.#	Brake output
8.23	T26 digital I/O 3 source/destination	9.05	9.05	para.#	Up direction
8.24	T27 digital input 4 destination	6.33	6.33	para.#	Down direction
8.25	T28 digital input 5 destination	1.45	1.45	para.#	Speed ref. A
8.26	T29 digital input 6 destination	1.46	1.46	para.#	Speed ref. B
8.28	T22 24V output source	0.00	0.00	para.#	
8.31	T24 digital I/O 1 output select	OFF	OFF		Set T24 as input
8.32	T25 digital I/O 2 output select	On	On		Set T25 as output
9.04	Logic function 1 source 1	6.33	6.33	para.#	(menu 9 functions )
9.06	Logic function 1 source 2	12.01	12.01	para.#	(are used to interlock )
9.10	Logic function 1 destination	6.34	6.34	para.#	(up & down inputs )
9.14	Logic function 2 source 1	2.03	2.03	para.#	(and to ensure that )
9.16	Logic function 2 source 2	2.03	2.03	para.#	(a speed is selected )
9.19	Logic function 2 delay	-2	-2	s	(before brake lifts )
10.30	Full power braking time	0	0	s	(Disable internal )
10.31	Full power braking period	0	0	s	(DBR trips )

## Operating Instructions

Par #	Description	O.Lp Setting	C.Lp Setting	Units	Note
11.04	Parameter 0.14 set up	1.22	1.22	para.#	
11.05	Parameter 0.15 set up	1.25	1.25	para.#	
11.06	Parameter 0.16 set up	1.26	1.26	para.#	
11.07	Parameter 0.17 set up	2.22	2.22	para.#	
11.08	Parameter 0.18 set up	2.23	2.23	para.#	
11.09	Parameter 0.19 set up	12.24	12.24	para.#	
11.10	Parameter 0.20 set up	12.42	12.47	para.#	
11.11	Parameter 0.21 set up	12.44	12.45	para.#	
11.12	Parameter 0.22 set up	12.46	12.46	para.#	
11.13	Parameter 0.23 set up	12.47	12.48	para.#	
11.14	Parameter 0.24 set up	12.45	3.38	para.#	
11.15	Parameter 0.25 set up	6.01	3.34	para.#	
11.16	Parameter 0.26 set up	6.06	3.36	para.#	
11.17	Parameter 0.27 set up	6.07	3.42	para.#	
11.18	Parameter 0.28 set up	5.23	4.12	para.#	
11.31	User Drive Mode	OPEnLP	CLVEct		Drive mode
12.03	Threshold detector 1 source	1.5	1.5	para.#	
12.04	Threshold detector 1 level	15	15	%	
12.06	Threshold detector 1 output invert	On	On		
12.23	Threshold detector 2 source	5.01	3.02	para.#	Motor speed
12.24*	Threshold detector 2 level	15	15	%	ADO speed threshold
12.26	Threshold detector 2 output invert	On	On		
12.41	Brake controller enable	d IO	d IO		Assign brake control (T25)
12.42*	Upper current threshold	20	n/a	%	(refer to section on )
12.45*	Brake apply frequency / speed	0.5	n/a	Hz	(brake set-up before )
12.46*	Pre-brake release/Brake apply speed delay	0.3	0.3	s	(adjusting these )
12.47*	Post brake release delay	0.3	0.3	s	(parameters )
12.48*	Brake apply delay	n/a	0.3	s	( )
14.02	PID main reference source	2.22	2.22	para.#	S-ramp run ref.
14.03	PID reference source	2.23	2.23	para.#	S-ramp start ref.
14.08	PID enable	On	On		Enable s-ramp controls
14.09	PID optional enable source	9.02	9.02	para.#	Input interlocks active
14.11	PID I gain	0	0		
14.16	PID output destination	2.07	2.07	para.#	Sets max. rate of accel

Parameters marked with \* should be tuned to meet specific site requirements

#0.19 (12.24) should be adjusted to set the pre-open door threshold to 0.3m/s max. (e.g. If lift speed = 1.0m/s, then #0.19 = 30% (max.)).

### 13.3 Smart card programming

The control unit is delivered ready-programmed by the manufacturer but can be easily set up by using a smart card in the case where the drive mode needs to be changed or if the drive must be replaced.

To check whether programming has been carried out, look at parameter #0.29. In a programmed controller this has the value 1 but is otherwise 0.

The original data set was programmed on SP2403(11kW) inverter. When programming other drive sizes, the message "C.rtg" may be displayed and if an option module is fitted inside the drive, the message "C.Optn" may be displayed. These messages must be acknowledged by pressing the RED Reset button on the keypad.

The smart card will normally contain the inverter settings when the controller is delivered, stored as data set 1.

#### 13.3.1 Saving/restoring complete parameter sets to/from the Smartcard

To store a complete parameter set on a Smartcard

Set #xx.00 to a value of 3yyy

- e.g. Your closed loop lift setup could be 3002 (i.e. data set 2)  
Your open loop lift setup could be 3003 (i.e. data set 3) etc...

If a data set already exists in a location that you wish to update, first delete the existing settings by

Set #xx.00 to a value of 7yyy

- e.g. To delete your closed loop lift setup would be 7002  
To delete your open loop lift setup would be 7003 etc...

The new data set can then be stored as above

To view what each file is on the smartcard

Go to #11.37 - This will scroll through the parameter sets on the card. If it does not scroll you only have 1 parameter file.

Once you have selected which smartcard file you are looking at go to #11.38 - This tells you which control mode the smartcard parameters are saved for.

To read a complete parameter set back into the drive

Set #xx.00 to a value of 6yyy

- e.g. Your closed loop lift parameters would be restored from 6002  
Your open loop lift parameters would be restored from 6003 etc...

For a detailed description on SMARTCARD Operation see section 9 of the Unidrive SP User Guide.



### 13.4 Inverter start-up on site

Start-up can be carried out on site in just a few steps as follows

- Enter Motor Nameplate Details
- Set Contract Parameters
- Auto-tuning
- Optimising starting
- Optimising the travel curve
- Optimising the motor slip
- Optimising stopping
- Optimising the brake controller

#### 13.4.1 Enter Motor Nameplate Details

The following values must be set based on the motor data plate values

- #0.42 Number of poles (set to "Auto" for drive to auto-calculate)
- #0.43 Motor power factor / cos phi (auto-calculated with rotating auto-tune)
- #0.44 Rated motor voltage (check if motor is Star or Delta connected)
- #0.45 Rated motor speed (rpm)
- #0.46 Rated motor current (A)
- #0.47 Rated motor frequency (Hz)

#### 13.4.2 Set Contract Parameters

The following values must be set based on the lift contract speed/rated motor speed, all references should be in "Hz" for O.Lp operation or "rpm" for C.Lp operation.

- #0.02 = Maximum reference clamp (Hz/rpm)
- #0.03 =  $(100 / \#1.28) * (V\_norm / aACCEL)$  ;(s/100Hz or s/1000rpm)
- #0.04 =  $(100 / \#1.28) * (V\_norm / aDECEL)$  ;(s/100Hz or s/1000rpm)
- #1.22 =  $(V\_insp.lo / V\_norm) * \#1.28$  ;For inspection speed of 0.3m/s and lift speed 1.0m/s with 50Hz motor, then  $(0.3m/s / 1.0m/s) * 50Hz = 15Hz$
- #1.23 =  $(V\_insp.hi / V\_norm) * \#1.28$  ;where  $V\_insp.hi = 0.5m/s$
- #1.24 =  $(V\_lev / V\_norm) * \#1.28$  ;For levelling speed of 0.05m/s and lift speed 1.0m/s with 50Hz motor, then  $(0.05m/s / 1.0m/s) * 50Hz = 2.5Hz$
- #1.25 =  $(V\_relev / V\_norm) * \#1.28$  ;where  $V\_relev = 0.05m/s$
- #1.26 =  $(V\_hs1 / V\_norm) * \#1.28$  ;where  $V\_hs1 = 1.0m/s$  max.
- #1.27 =  $(V\_hs2 / V\_norm) * \#1.28$  ;where  $V\_hs2 = 1.0m/s$  max.
- #1.28 = Motor frequency/speed for  $V\_norm$  ;assuming contract speed is achieved at rated motor speed ).

Where;  $V\_norm$  = Rated speed in m/s  
 $aACCEL$  = Acceleration ( $m/s^2$ )  
 $aDECEL$  = Deceleration ( $m/s^2$ )

## Operating Instructions

**13.4.3 Auto-tuning**

Auto-tuning is essential for good performance of the lift motor. Therefore, if auto-tuning has not previously been performed, change parameter **#0.40 = 1** (static) or **2** (rotating) and then press the UP or DN button on the EMOP control pendant and hold until parameter **#0.40 = 0**, the auto-tune is now complete.

If the auto-tune terminates early, an error code will appear on the inverter screen. Check the meaning of the code in the UnidriveSP user guide and rectify the problem before attempting to perform the auto-tune again.

***Please note:***

It is advisable that the rotating autotune is carried out for optimum performance, especially for open loop operation. However, before a rotating autotune is performed, it is necessary to remove all load from the motor (i.e. support the lift and remove the ropes from the sheave).

**13.4.4 Setting the current limits**

The current limit parameters may be changed automatically by the autotune process so it is advisable to check the following settings before proceeding further.

Motoring current limit           **#4.05**  
Regen current limit               **#4.06**  
Symmetrical current limit       **#4.07**

The motoring current limit applies in either direction of rotation when the machine is producing motoring torque and similarly the regen current limit applies in either direction when the machine is producing regenerating torque. The symmetrical current limit can override either motoring or regenerating current limit if it is set at a lower value than either limit.

Therefore, it is necessary to change all of the above parameters to the same value when setting the current limits.

**13.4.5 Optimising the travel curve**

Optimise starting by means of a separately adjustable starting S ramp. This is set up via **#0.18** and additional to the standard S-ramp jerk rate set in **#0.17**. Increase the setting if the lift starts with a jerk and decrease it if the lift is sluggish during initial acceleration.

The default acceleration and deceleration rates are set to  $0.5\text{m/s}^2$  for open loop operation or  $0.75\text{m/s}^2$  for closed loop operation.

Adjust acceleration **#0.03** until you obtain the most comfortable start and adjust deceleration **#0.04** to optimise the slowdown profile (i.e. ensure that a constant levelling speed is achieved before the stop signal is given, but also ensure that the levelling time does not exceed 2-3secs).

Reduce **#0.03/#0.04** for harder accel/decel or increase **#0.03/#0.04** for softer accel/decel.

**13.4.6 Adjusting the speed controller (Closed loop only)**

Start the lift using EMOP or car-top test and perform the following steps to adjust the speed controller;

- Adjusting the speed controller P gain           Increase **#0.07** in steps of 0.01 until noisy or unstable
- On hearing controller noise (increments)       Increase current filter **#0.27** in steps of 1ms up to 5ms max., then increase **#0.07** in further steps of 0.01 until unstable.
- On obtaining instability                           Reduce **#0.07** to 60% of the unstable value
- Adjusting the speed controller I gain           Increase **#0.08** from 1.0 to max. 5.0

---

---

subject to change without notice!

---

---



**13.4.7 Optimising the motor slip (Open loop only)**

The motor rated rpm (motor slip value) #0.45 must be set correctly to allow the correct relationship between the magnetising and torque producing currents. If the magnetising current is too low then the motor will be under excited and if it is too high the torque producing current will be limited, both cases resulting in poor motor control.

A simple method of checking that the slip value is correct is to run the lift at levelling speed with empty car. If the motor rated speed is set correctly the motor speed in both directions should be the same due to the correct level of slip compensation being applied.

If the motor speed is slower when the lift is travelling in the down direction, then #0.45 should be increased in small increments until the speeds are roughly equal.

If the motor speed is slower when the lift is travelling in the up direction, then #0.45 should be decreased in small increments until the speeds are roughly equal.

**13.4.8 Optimising stopping (Open Loop only)**

The stopping mode of the motor has plays an important role in the floor levelling accuracy of the lift and can be adjusted to suit the particular characteristics of the motor being controlled.

The preferred stopping mode for most lift machines is mode 1 (Ramp).

However, ramping down to stop on some higher slip motors (e.g. old polechanger type motors) can result in a loss of torque under load at low frequencies. This results in poor floor levelling accuracy due to loss of control. In this case it may be necessary to change to stopping mode 4 (Timed DC injection braking stop). Using this methods will stop the motor more abruptly but will help to maintain floor levelling accuracy under different load conditions.

Stopping methods options (mode 0 should not be used under any circumstances).

Stopping Mode	Phase 1	Phase 2	Comments
0: Coast	Inverter disabled	Drive cannot be re-enabled for 1s	Delay in phase 2 allows rotor flux to decay.
1: Ramp	Ramp down to zero frequency	Wait for 1s with inverter enabled	
2: Ramp followed by DC injection	Ramp down to zero frequency	Inject DC at level specified by #6.06 for time defined by #6.07	
3: DC injection with zero speed detection	Low frequency current injection with detection of low speed before next phase.	Inject DC at level specified by #6.06 for time defined by #6.07	The drive automatically senses low speed and therefore it adjusts the injection time to suit the application. If the injection current level is too small the drive will not sense low speed (normally a minimum of 50-60% is required).
4: Timed DC injection braking stop	Inject DC at level specified by #6.06 for time defined by #6.07.	No phase 2.	

## Operating Instructions

**13.5 Optimising the brake controller**

The brake is controlled by the Unidrive SP brake function (activated with #12.40). The brake contactor K3 is switched by the output at terminal 25 which is controlled by internal logic based on the timing diagram below.

**13.5.1 In Closed Loop Mode**

The post-brake release time (#12.47) is used to allow for the brake release time. From the time that the drive is enabled and then during this period the speed reference is held constant at zero, so that there is no sudden increase in motor speed when the brake actually releases.

Closed Loop Brake Sequence

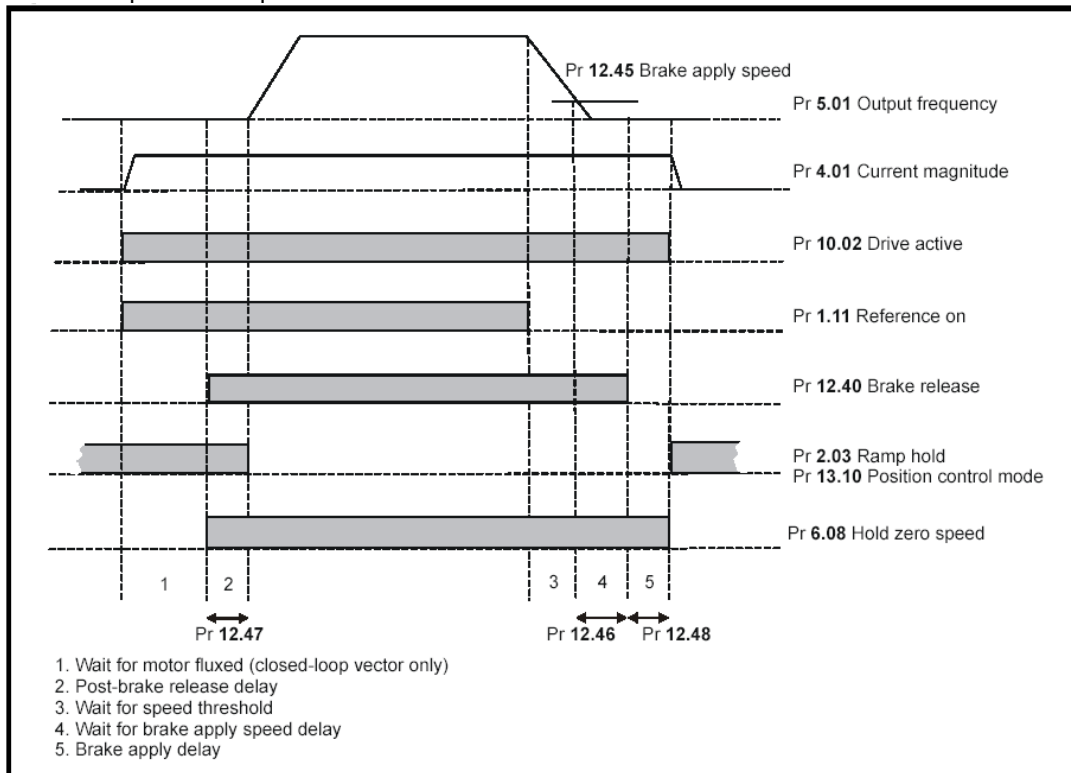

When stopping, the drive reference is removed (#1.11=0), but the brake will remain energised (open) until the motor has remained at a speed below the brake apply speed (#12.45) for the delay (#12.46). The delay prevents rapid activation and de-activation of the brake when fine control of a motor is required close to zero speed.

The brake apply delay (#12.48) is used to allow for the brake application time. During this period the drive holds zero speed (#6.08=1), and so the drive is enabled with zero speed reference. This ensures that the motor remains stationary while the brake is being applied.

Operating Instructions

### 13.5.2 In Open Loop Mode

The current magnitude is compared to an upper threshold (#12.42) and a lower threshold (#12.43) by a comparator with hysteresis to give torque present and drive output open detection functions respectively. The upper and lower threshold currents are given as a percentage of motor current defined by #5.07. The upper threshold should be set to the current level that indicates that there is magnetising current and sufficient torque producing current in the motor to deliver the required amount of torque when the brake is released. The output of the comparator remains active after this level has been reached unless the current subsequently falls below the lower threshold which should be set to the required level to detect the condition where the motor has been disconnected from the drive. If the lower threshold is set greater or equal to the upper threshold, the upper threshold applies with a hysteresis band of zero. If #12.42 and #12.43 are both set to zero then the output of the comparator is always one.

The frequency comparator (#12.44) is used to detect when the motor frequency has reached a level where the motor can produce the required amount of torque to ensure that the motor rotates in the demanded direction when the brake is released. This parameter should be set to a level slightly above the motor slip frequency that is likely to occur under the highest expected load that is applied to the motor when the brake is released.

#### Open loop brake sequencing

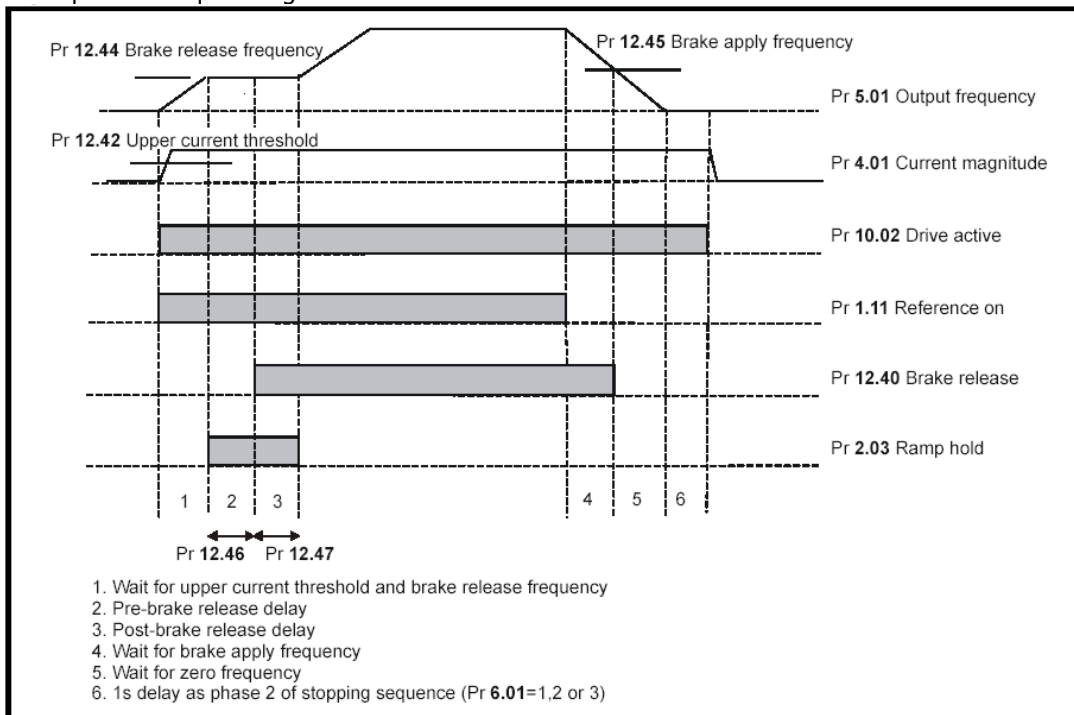

The brake apply frequency threshold (#12.45) is used to ensure that the brake is applied before the motor frequency reaches zero and to prevent the motor rotating (in the reverse direction due to an overhauling load for example) during the brake apply time. If the frequency falls below this threshold, but the motor is not required to stop (i.e. reversing direction without stopping), provided the Reference on parameter (#1.11) remains at one, the brake is not applied. This prevents the brake from activating and de-activating as the motor passes through zero speed.

subject to change without notice!



## Operating Instructions

The pre-brake release delay (#12.46) is used to allow time for the motor torque to reach the required level before the brake is released. This time should allow for the motor flux to reach a significant proportion of the rated level (2 or 3 times the rotor time constant of the motor), and the time for slip compensation to become fully active (at least 0.5s). During the Pre-brake delay period the frequency reference is held constant (#2.03 = 1).

The post-brake release delay (#12.47) is used to allow for the brake release time. During this period the frequency reference is held constant (#2.03 = 1), so that there is no sudden increase in motor speed when the brake actually releases.

For more detailed information on the inverter please consult the "UnidriveSP User Guide" which can be found on the Lifteknik website, or on the CD supplied in the Qube documentation pack.



**Lifteknik Limited**

11 Victoria Road • Chester • Cheshire CH2 2AX  
Tel. +44(0)1244 389690 • Fax. +44(0)1244 389691  
*e-mail:sales@lifteknik.co.uk*

---

---

subject to change without notice!

---

---

